

## OVERVIEW

The ST5484E is a self-contained seismic velocity transmitter that incorporates a piezoelectric accelerometer, signal integrator, RMS peak detector, and a 4-20 mA signal conditioner into a single package. It can be mounted directly on a machine case or bearing housing without intervening signal conditioning equipment. The amplitude of the integrated acceleration (velocity) signal is converted to a proportional 4-20 mA signal compatible with industrial process control instrumentation such as PLCs, DCSs, and SCADA systems that can provide trending and/or alarming capabilities for a simplified vibration monitoring strategy.

When the flying lead or terminal block connector options are chosen, the transmitter does not need a separate environmental housing and can directly accept conduit. To reduce installed cost, it can be used with barriers for intrinsically safe installations, or wired directly to explosion-proof conduit fittings for explosion-proof installations.



### Need A Local Display?

When continuous, local indication of vibration levels is required at the transmitter, the Metrix ST5491E provides these capabilities.

Its sensing and transmitter elements are similar to the ST5484E, but it includes a convenient 2½ digit LCD display in an integral conduit elbow and is rated for use in temperatures from -10°C to +70°C. Refer to Metrix datasheet 1004598 for ordering information and detailed specifications.

## APPLICATIONS

A vibration transmitter may be appropriate in applications where a stand-alone monitoring system may not be warranted.

The ST5484E handles general-purpose vibration measurements on a wide range of rotating and reciprocating machinery with rotational speeds between 120- and 6,000-rpm. Seismic measurements are suitable for machines with rolling-element bearings because shaft vibration in such machines is usually transmitted directly through the bearing to the bearing housing without substantial damping or attenuation. Seismic transducers can also measure vibration that does not originate at the shaft, such as bearing-related wear and defects, footing/foundation problems, piping resonances that are coupled to the machine, etc.

### Why Measure Velocity?

Acceleration and displacement levels are heavily influenced by the frequencies at which the vibration is occurring, while velocity levels are much less influenced. Thus, although acceleration,



**Flying Leads**  
(Option D=0, 1, 5, or 6) (2-wire shown; 4-wire also available)



**2-Pin Terminal Block**  
(Option D=2)



**4-Pin Terminal Block**  
(Option D=3)



**2-Pin MIL Connector**  
(Option D=4)

### Explosion Proof Versions with Options D=2 & 3

**Note: Units sold with an explosion proof rating will include an 8200-000 IEC explosion proof elbow that will be affixed at the factory.**



velocity, and displacement measurements are inter-related mathematically, seismic velocity measurements tend to be more consistent over a wide range of frequencies than either displacement or acceleration. Consequently, broadband (sometimes called “overall” or “unfiltered”) velocity measurements are appropriate for monitoring many machines as a reliable indicator of damaging vibratory energy, with the notable exception of machines with fluid-film bearings, which are usually better addressed by shaft-observing proximity probes.

Casing displacement is not a practical measurement to make directly and is typically just an integrated seismic velocity measurement. As such, the primary decision when selecting a seismic sensor will usually be whether to measure casing velocity or casing acceleration. As noted above, casing velocity will often be more appropriate because it tends to be a more reliable indicator of damaging vibratory energy over a broad frequency spectrum for low- to medium-speed machinery.



**NOTE:** For machines with fluid-film bearings, shaft-observing proximity probes will provide more effective vibration measurements than seismic transducers due to the rotor dynamics of the machine and the attenuation of vibratory energy through a fluid-film boundary. Accordingly, Metrix recommends and provides proximity probes and associated 4-20 mA transmitters or monitoring systems for such applications.

For machines with rolling element bearings and running above 6,000 rpm, and/or where impulsive casing vibration occurs, acceleration may be a better measurement. In such situations, it is recommended that you consult with a Metrix sales professional who can review your application and assist with selection of the proper transducer type and associated transmitter or monitoring system.

## FEATURES

- **RFI/EMI Immunity** – Enhanced circuit design and installation techniques aggressively filter out noise from common sources such as handheld radios
- **Excellent Moisture Resistance** – The 2-pin MIL connector version is hermetically sealed to provide an IP67-rated enclosure. Flying lead and terminal block versions are fully potted and rated to IP66 when installed with optional IEC conduit elbow
- **Hazardous Area Approvals** – North American (CSA), Brazilian (INMETRO), and European (ATEX & IEC) approvals available
- **Dynamic Signal Availability** – 2-wire versions provide a 4-20 mA velocity- proportional signal for easy connection to PLCs, DCSs, and other plant control systems. Optional 4-wire versions<sup>1</sup> also provide the raw acceleration signal (100 mV/g) for use with vibration data collectors and analyzers
- **Variety of Connection Options** – Flying leads, terminal block, and MIL-type connectors available
- **Conduit-Ready<sup>2</sup>** – Terminal block and flying lead options have conduit threads on top of sensor. No special housings are required for connection of conduit
- **Rugged, Industrial Design** – Robust construction offers outstanding durability; built-in base and housing strain protection helps ensure that over-torqueing sensor-to- machine and sensor-to-conduit connections won't damage internals or body
- **High- and Low-Pass Filter Options** – The ST5484E can be ordered with a wide variety of low- and high-pass filter options to precisely tailor the band over which vibration is measured
- **Polarity-Independent Wiring** – Metrix patented IPT® technology allows loop power to be connected without regard to voltage polarity, reducing field wiring errors and ensuring that the raw acceleration output<sup>1</sup> is not phase inverted
- **Multiple Mounting Options** – Integral and removable mounting stud options available in both metric and English thread sizes; flat base mounting adapters are also available
- **Loop-Powered** – Runs on nominal 24 V<sub>DC</sub> power supplied by the 4-20 mA current loop
- **Wide Supply Voltage Range** – Accepts loop power voltages from 11 to 29.6 V<sub>DC</sub> (intrinsically safe) or 30.0 V<sub>DC</sub> (explosion proof & non-incendive)

## ST5484E Seismic Velocity 4-20 mA Transmitter

Datasheet

- **RMS Amplitude Detection** – Measures Root Mean Square (RMS) vibration amplitude. Options available for True RMS or scaled RMS (RMS x √2) for “derived peak”
- **Numerous Full Scale Ranges** – The full scale ranges provided in option AAA reflect frequently-ordered ranges; however, many others (too numerous to list) are also available. Consult factory for applications requiring other full scale ranges

### Notes:

1. Dynamic raw acceleration signal available with 4-wire versions only (ordering options D= 1 and D=3).
2. Metrix recommends flexible (rather than solid) conduit when possible. Solid conduit can introduce preload forces on the sensor and alter of the vibration response of the sensor.

## SPECIFICATIONS

All specifications are at +25°C (+77°F) and +24 V<sub>DC</sub> supply voltage unless otherwise noted.

Inputs	
<b>Supply Voltage (see also note under max loop resistance)</b>	11 – 29.6 V <sub>DC</sub> (24 V <sub>DC</sub> nominal) (intrinsically safe); 11 – 30 V <sub>DC</sub> (24 V <sub>DC</sub> nominal) (explosion proof and non-incendive); Metrix patented IPT® independent polarity diode bridge circuit allows voltage to be connected without regard to polarity
<b>Circuit-to-Case Isolation</b>	500 Vrms
Outputs	
<b>4-20 mA</b>	Proportional to velocity full scale range (4mA = 0 vibration, 20mA = full scale vibration)
<b>Maximum 4-20 mA loop resistance</b>	$R_L = 50 \times (V_s - 11) \Omega$ where $V_s$ = Supply Voltage at transmitter terminals.  NOTE: For every 50 Ω of resistance in the 4-20 mA loop, 1 V <sub>DC</sub> above the minimum supply voltage (11 V <sub>DC</sub> ) must be available at the transmitter terminals. For example, 12 V <sub>DC</sub> at the transmitter terminals will allow a 50 Ω loop resistance; 30 V <sub>DC</sub> at the transmitter terminals will allow a 950 Ω loop resistance. For intrinsically safe applications, the use of a passive zener barrier will incur a voltage drop of approximately 8.1 volts at the barrier, and the loop supply voltage is limited to 26 V <sub>DC</sub> . Thus, with passive barriers and a 26 V <sub>DC</sub> supply, the maximum available voltage at the transmitter will be 17.9 V <sub>DC</sub> and the corresponding maximum loop resistance will be 345 Ω.
<b>Dynamic Signal</b>	100 mV/g (10.2 mV / m/s <sup>2</sup> ) acceleration, filtered to same frequency band as proportional velocity (see ordering options E & F)

# ST5484E Seismic Velocity 4-20 mA Transmitter

Datasheet

<b>Dynamic Signal Output Impedance</b>	10 kΩ  <b>NOTES:</b> 1. The dynamic signal output is short-circuit protected by means of a 10 kΩ resistor, resulting in a relatively large output impedance. Many data collectors and analyzers have relatively low input impedances (100 kΩ or less) which will load this dynamic output and attenuate the signal by 10% or more. Refer to Table 1 for the dB and percentage attenuation for various load impedances.  2. Because the ST5484E is a loop-powered device with low operating power, the dynamic signal output requires a buffer amplifier for cable runs in excess of 16 feet (5 meters). Longer cable runs will also introduce distributed cable capacitance that acts as a low-pass filter, attenuating high-frequency signal content. In such situations, consult the factory for assistance selecting an appropriate low-capacitance cable.
<b>Recommended Minimum Load Impedance (Zload) for Dynamic Signal Connection</b>	500 kΩ (see also note 1 above)
<b>Signal Processing</b>	
<b>Frequency Response (+/- 3dB passband)</b>	2 Hz – 1500 Hz (standard) 2 Hz – 2000 Hz (optional)
<b>Optional High-Pass Filter Corner</b>	5, 10, 20, 50, 100, or 200 Hz (must be specified at time of ordering)
<b>High-Pass Roll-Off</b>	12 dB / octave
<b>Optional Low-Pass Filter Corner</b>	230, 250, 350, 450, 500, or 1000 Hz (must be specified at time of ordering)
<b>Low-pass Roll-Off</b>	12 dB / octave
<b>Accuracy</b>	± 2.5% (within passband) ± 4% (at corner frequencies)
<b>Maximum Full Scale</b>	5.0 in / sec (others by request)
<b>Minimum Full Scale</b>	0.5 in / sec (others by request)
<b>Full Scale Range Units</b>	• in / sec (standard) • mm / sec (available by request)
<b>Amplitude Detection</b>	True RMS detector; full scale may be ordered with True RMS units or scaled RMS (RMS x √2) for “derived peak” measurements  See ordering option AAA.

Physical	
<b>Operating Temperature</b>	-40°C to +100°C (-40°F to +212°F)
<b>Weight</b>	0.9 lbs (0.36 kg)
<b>Dimensions</b>	Refer to Figures 1 and 2 on page 8
<b>Sensitive Axis</b>	Same as mounting stud axis
<b>Axis Orientation</b>	Any
<b>Enclosure Material</b>	<ul style="list-style-type: none"> <li>• 303 stainless steel (standard)</li> <li>• 316 stainless steel (optional)</li> </ul>
<b>Enclosure Rating</b>	<b>MIL-Style Connector (option D=4):</b> <ul style="list-style-type: none"> <li>• IP67 and NEMA 4X</li> </ul> <b>Flying Leads and Terminal Block Connectors (option D≠4):</b> <ul style="list-style-type: none"> <li>• <b>IP66</b> when used with the following conduit elbows: 8200-001-IEC, 8200-003-IEC, 8200-008-IEC,</li> <li>• <b>No Rating*</b> when used with the following conduit elbows: 8200-001, 8200-003, 8200-005, 8200-008, 8200-101, 8200-103, 8200-108</li> </ul> <p>* <b>NOTE:</b> IP and NEMA ratings pending; refer to table on page 6.</p>
<b>Connector Types</b>	<ul style="list-style-type: none"> <li>• Flying Leads (2- and 4-wire)</li> <li>• MIL-C-5015 (2-wire only)</li> <li>• Terminal Block (2- and 4-wire)</li> </ul>
<b>Humidity</b>	<ul style="list-style-type: none"> <li>• 95%, non-condensing (flying lead and terminal block versions)</li> <li>• 100% condensing (MIL-style connector)</li> </ul>
Approvals	
<b>CE Mark</b>	• Yes
<b>Hazardous Areas</b>	<ul style="list-style-type: none"> <li>• CSA</li> <li>• ATEX</li> <li>• IECEx</li> <li>• INMETRO</li> <li>• KOSHA</li> <li>• Custom Union EAC</li> </ul>
Recommended IS Barriers	
<b>Passive (Zener Type)</b>	MTL 7787+ or equal
<b>Active (Zener Type)</b>	MTL 7706 or equal
<b>Active (Galvanic Type)</b>	MTL 5541 or equal
<b>ST5484E Entity Parameters</b>	<ul style="list-style-type: none"> <li>• Vmax: 29.6 V<sub>DC</sub> (intrinsically safe)</li> <li>• Vmax: 30 V<sub>DC</sub> (explosion proof and non-incendive)</li> <li>• Imax: 100 mA</li> </ul>

ORDERING INFORMATION

AAA-BBCD-EF

ST5484E- □□□-□□□□-□□

AAA				Full Scale Range <sup>1</sup>
	1	2	1	1.0 in/sec (25.4 mm/s) peak <sup>2</sup>
	1	2	2	0.5 in/sec (12.7 mm/s) peak <sup>2</sup>
	1	2	3	2.0 in/sec (50.8 mm/s) peak <sup>2</sup>
	1	2	4	5.0 in/sec (127 mm/s) peak <sup>2</sup>
	1	2	6	0.8 in/sec (20.3 mm/s) peak <sup>2</sup>
	1	3	2	3.0 in/sec (76.2 mm/s) peak <sup>2</sup>
	1	5	1	1.0 in/sec (25.4 mm/s) true RMS
	1	5	2	0.5 in/sec (12.7 mm/s) true RMS
	1	5	3	2.0 in/sec (50.8 mm/s) true RMS
	1	5	4	5.0 in/sec (127 mm/s) true RMS
	1	5	6	0.8 in/sec (20.3 mm/s) true RMS
	1	6	2	3.0 in/sec (76.2 mm/s) true RMS
BB	Housing Material & Stud Size <sup>1</sup>			
	00	303 SS housing, ¼" NPT stud		
	01	303 SS housing, ½" NPT stud		
	02	303 SS housing, ⅜ x 24 UNF – ½" stud		
	03	303 SS housing, ½ x 20 UNF – ½" stud		
	04	303 SS housing, M8 x 1.0 – 12 stud		
	05	303 SS housing, M10 x 1.25 – 12 stud		
	06	303 SS housing, ¼ x 20 UNC – ½" stud		
	07	303 SS housing, ¼ x 28 UNF – ½" stud		
	08	303 SS housing, M8 x 1.25 – 12 stud		
	09	303 SS housing, ⅜ x 16 UNC – ½" stud		
	10	316 SS housing, ¼" NPT stud		
	11	316 SS housing, ½" NPT stud		
	12	316 SS housing, ⅜ x 24 UNF – ½" stud		
	13	316 SS housing, ½ x 20 UNF – ½" stud		
	14	316 SS housing, M8 x 1.0 – 12 stud		
	15	316 SS housing, M10 x 1.25 – 12 stud		
	16	316 SS housing, ¼ x 20 UNC – ½" stud		
	17	316 SS housing, ¼ x 28 UNF – ½" stud		
	18	316 SS housing, M8 x 1.25 – 12 stud		
	19	316 SS housing, ⅜ x 16 UNC – ½" stud		
	20	303 SS housing, ½ x 13 UNC – ½" stud		
	30	316 SS housing, ½ x 13 UNC – ½" stud		

C		Hazardous Area Certification <sup>3,4,5</sup>
	0	No Hazardous Approval Area
	1	CSA US/C, Class I, Div 2, Grps A-D (non-incendive)
	2	CSA US/C, Class I, Div 1, Grps B-D and Class II, Div 1, Grps E-G (explosion proof)
	3	ATEX, Ex ia IIC T4 Ga (intrinsically safe)
	4	CSA US/C, Class I, Div 1, Grps A-D (intrinsically safe)
	5	INMETRO, Ex ia IIC T4 Ga (intrinsically safe)
	6	INMETRO, Ex d IIC T4 Gb (explosion proof)
	7	IECEX/KOSHA Ex ia IIC T4 Ga (intrinsically safe) 16-AV4BO-0214X
	8	ATEX/IECEX/KOSHA Ex d IIC T4 Gb (explosion proof) 16-AV4BO-0213X
	A	EAC, Ex ia IIC T4 Ga (intrinsically safe), Ex d IIC T4 Gb (explosion proof)
	B	ATEX/EAC, Ex ia IIC T4 Ga (intrinsically safe)
D	Connection Type <sup>3</sup>	
	0	24" Flying Leads, 2-wire; (4-20 mA output only)
	1	24" Flying Leads, 4-wire; (4-20 mA output and dynamic raw acceleration signal)
	2	Terminal Block, 2-wire <sup>6</sup> ; (4-20 mA output only)
	3	Terminal Block, 4-wire <sup>6</sup> ; (4-20 mA output and dynamic raw acceleration signal)
	4	2-Pin MIL-Style (MIL-C-5015); (4-20 mA output only)
	5	72" Flying Leads, 2-wire; (4-20 mA output only)
	6	72" Flying Leads, 4-wire; (4-20 mA output and dynamic raw acceleration signal)
E	High-Pass Filter	
	0	2 Hz (standard)
	1	5 Hz
	2	10 Hz
	3	20 Hz
	4	50 Hz
	5	100 Hz
	6	200 Hz <sup>7</sup>
	X	Custom (consult factory) <sup>7</sup>

F	Low-Pass Filter
0	1500 Hz (standard)
1	500 Hz
2	1000 Hz
3	2000 Hz
4	250 Hz <sup>7</sup>
5	230 Hz <sup>7</sup>
6	350 Hz <sup>7</sup>
7	450 Hz
X	Custom (consult factory) <sup>7</sup>

**NOTES:**

- Smaller-diameter mounting studs are not able to withstand sustained ambient vibration levels above 2.0 in/sec. Consult Table 2 for allowable combinations of A and B options.
- The ST5484E uses an RMS amplitude detection circuit. Full scale ranges in peak units use scaled RMS (i.e., RMS x √2). The “derived peak” measurements will equal true peak only under the special case of a pure sinusoid, not complex vibration signals.
- Hazardous Area Certifications are not compatible with all connection types. Consult Table 3 for allowable combinations of C & D options.
- Some approvals require intrinsic safety barriers, others require Explosion-Proof wiring practices. Refer to Table 4.
- ATEX/IECEX/INMETRO Ex d (flameproof) approvals (ordering option C=8 or C=6) require conduit elbow 8200-AAA-IEC, sold separately.
- Refer to the Accessories section of this document. Units sold with an explosion proof rating will include an 8200-000 IEC explosion proof elbow that will be affixed at the factory.
- High- and Low-Pass filter corners for standard filters must be separated by at least one octave (low-pass frequency must be at least twice the high-pass frequency). All combinations are allowed except E = 6 and F = 4, 5, or 6. Custom filters with closer separation and/or different roll-offs may be available in some instances. Consult the factory if custom filters are required.

Table 1 – Attenuation of Dynamic Signal versus Load Impedance ( $Z_{load}$ )		
Data Collector / Analyzer Load Impedance ( $Z_{load}$ )	Dynamic Signal Voltage Attenuation (dB)	Dynamic Signal Voltage Attenuation (%)
10 MΩ	0.01 dB	0.1%
5 MΩ	0.02 dB	0.2%
2 MΩ	0.04 dB	0.5%
1 MΩ	0.09 dB	1%
500 kΩ	0.18 dB	2%
200 kΩ	0.43 dB	5%
100 kΩ	0.84 dB	9%
50 kΩ	1.61 dB	17%
20 kΩ	3.57 dB	33%
10 kΩ	6.10 dB	50%

**Table 2 – Allowable Combinations for AAA & BB Options**

Full Scale Range AAA =	Allowable BB options (Mounting Stud Sizes)
121, 122, 123, 126, 151, 152, 153, 156	All (no restrictions)
124 and 154	00, 01, 03, 10, 11, 13
132 and 162	00, 01, 02, 03, 05, 09, 10, 11, 12, 13, 15, 19

**Table 3 – Allowable Combinations for C & D Options**

C \ D	0	1	2	3	4	5	6	7	8	A	B
0	Y	Y	Y	Y	Y	Y	Y	Y	Y	Y	Y
1	Y	Y	Y	Y	Y	Y	Y	Y	Y	Y	Y
2	Y	Y	Y	Y	Y	Y	Y	Y	Y	Y	Y
3	Y	Y	Y	Y	Y	Y	Y	Y	Y	Y	Y
4	Y	Y	N	Y	Y	Y	N	Y	N	N	Y
5	Y	Y	Y	Y	Y	Y	Y	Y	Y	Y	Y
6	Y	Y	Y	Y	Y	Y	Y	Y	Y	Y	Y

**Table 4 – Approvals and corresponding wiring requirements**

C	Agency	Approved Areas	I.S. Barriers Required	Explosion-Proof Wiring Required	I.S Barriers or XP Wiring Not Required
1	CSA US/C	Class I, Div 2, Groups A-D (non-incendive)			•
2	CSA US/C	Class I, Div 1, Groups B-D; Class II, Div 1, Groups E-G (explosion proof)		•	
3	ATEX	Ex ia IIC T4 Ga (intrinsically safe)	•		
4	CSA	Class I, Div 1, Groups A-D (intrinsically safe)	•		
5	INMETRO	Ex ia IIC T4 Ga (intrinsically safe)	•		
6	INMETRO	Ex d IIC T4 Gb (explosion proof)		•	
7	IECEX / KOSHA	Ex ia IIC T4 Ga (intrinsically safe)	•		
8	ATEX / IECEX / KOSHA	Ex d IIC T4 Gb (explosion proof)		•	
A	EAC	Ex ia IIC T4 Ga (intrinsically safe) Ex d IIC T4 Gb (explosion proof)	•	•	
B	ATEX / EAC	Ex ia IIC T4 Ga (intrinsically safe)	•		

ACCESSORIES - ELBOWS

Conduit elbows are used with flying leads and terminal block versions of the ST5484E transmitter. They are not compatible with MIL-connector versions of the transmitter. A variety of available configurations accommodate English and metric conduit thread sizes, hazardous area approvals, materials of construction, and IP ratings. Note that not all configurations are available with hazardous area approvals or IP ratings. Consult the ordering information below. For ST5484E's that need an explosion proof (Ex d) rating, that are utilizing flying leads, Option D=0, 1, 5, & 6, the elbows (8200-001, 003, 005, 008, 101, 103, 108 and their IEC counterparts) must be used with a certified junction box or other certified connection location. For ST5484E's that need an explosion proof (Ex d) rating, utilizing integral terminal block, Option D=2 & 3, no junction box is necessary. Table 4 in the datasheet relates what hazardous area (Option C) is allowed per ST5484E Connection (Option D). ST5484E sold with an explosion proof rating (Ex d) will include a 8200-000 IEC explosion proof elbow and will be affixed at the factory.

AAA - B  
8200-□□□-□

ELBOWS								
A	A	A	B <sup>2,5</sup>	Conduit Fitting Size	Coating	Approvals	IP Rating (Elbow)	Material
0	0	0	IEC	1" NPT	Powder	ATEX/IECEX <sup>3,4</sup>	IP66	Copper-free aluminum
0	0	1		¾" NPT	Powder	CSA/UL <sup>1</sup>	NEMA4	Copper-free aluminum
0	0	1	IEC	¾" NPT	Powder	ATEX/IECEX <sup>3,4</sup>	IP66	Copper-free aluminum
0	0	3		½" NPT	Powder	CSA/UL <sup>1</sup>	NEMA4	Copper-free aluminum
0	0	3	IEC	½" NPT	Powder	ATEX/IECEX <sup>3,4</sup>	IP66	Copper-free aluminum
0	0	5		½" NPT	None	None	None	303 stainless steel
0	0	8		M20 x 1.5 metric	Powder	CSA/UL <sup>1</sup>	NEMA4	Copper-free aluminum
0	0	8	IEC	M20 x 1.5 metric	Powder	ATEX/IECEX <sup>3,4</sup>	IP66	Copper-free aluminum
1	0	1		¾" NPT	Powder + clear epoxy	CSA/UL <sup>1</sup>	NEMA4	Copper-free aluminum
1	0	3		½" NPT	Powder + clear epoxy	CSA/UL <sup>1</sup>	NEMA4	Copper-free aluminum
1	0	8		M20 x 1.5 metric	Powder + clear epoxy	CSA/UL <sup>1</sup>	NEMA4	Copper-free aluminum



Stainless steel elbows (models AAA=005)









Copper-free aluminum elbows (all models except AAA=005)





8200-000 IEC Reducers		
Part	Description	Material
91104-032	Reducer, 1"NPT(M) - ¾"NPT(F)	Nickle plated brass
91104-031	Reducer, 1"NPT(M) - ½"NPT(F)	Nickle plated brass
91104-022	Reducer, 1"NPT(M) - M20 X 1.5(F)	Nickle plated brass

NOTES:

- CSA approved through manufacturer (not Metrix) for the following areas:  
Class I, Div. 1 (Grps C & D)  
Class II, Div. 1 (Grps E, F & G)  
Class III
- B=IEC is only available for AAA=001, 003, and 008 at this time
- ATEX approved through manufacturer (not Metrix), (B=IEC)  
ITS09ATEX16417U  
Ex II2G, Ex d IIC  
CML 16ATEX1325X  
Ex II2GD, Ex db IIB Gb, Ex tb IIIC Db IP65 minimum
- IECEX approved through manufacturer (not Metrix)  
IECEXITS09.0024U  
Ex d IIC  
IECEX QPS 16.0012X  
Ex db IIB Gb, Ex tb IIIC IP66
- Elbow 8200-AAA-IEC is required for ST5484E installations meeting ATEX/IECEX/INMETRO/KOSHA/EAC Ex d (flameproof) hazardous area certifications

- UL approved through manufacturer (not Metrix) for the following areas:  
Class I; Div. 1 (Grps. B, C, D)  
Class II; Div. 1 (Grps. E, F, G)

	Part Number	Description
 <p>NOTE: Dielectric grease must be applied on the rubber boot connector to prevent moisture ingress.</p>	8978-111-XXXX	<p><b>2-pin MIL Splash-Proof (IP66) Cable Assembly</b>                      Used with 2-pin MIL style connector. Cable-to-sensor connection made by means of tight friction fit between cable molded boot and sensor - does not use threads. Connector is fully potted to provide IP66 seal against moisture ingress. 6.4mm (0.25") diameter polyurethane jacketed cable encapsulates a single twisted pair of conductors and shield.                      XXX.X = cable length in meters (example: 0035= 3.5 m)                      Min. cable length: 0.5m (XXXX=0005)                      Max. cable length: 999.5m (XXXX=9995)  <b>Note:</b> Must be ordered in increments of 0.5m</p>
	8978-211-XXXX	<p><b>2-pin MIL Cable Assembly</b>                      Similar to 8978-111 but without splash-proof boot and without IP66 rating; identical constraints on XXXX ordering options.</p>
	8978-200-0000	<p><b>2-pin MIL Connector Assembly</b>                      Similar to 8978-211 but without cable (connector can be disassembled for field installation of cable)</p>
	8978-311-XXXX	<p><b>2-pin MIL Submersible (IP67) Cable Assembly</b>                      Similar to 8978-111 but uses overmolded screw-type connector for IP67 rating. 4.9mm (0.19") diameter polyurethane jacketed cable encapsulates a single twisted pair of 20 AWG conductors and shield. Gold plated contacts, Stainless steel 316L Nut.                       XXX.X = cable length in meters (example: 0050= 5.0 m)  <b>NOTE:</b> only 5m, 10m, and 20m lengths available at this time. 5m length stock std; other length may incur longer lead times.</p>
	9334-111-XXXX-YYYY	<p><b>2-pin MIL Splash-Proof (IP66) Cable Assembly With Armor</b>                      Used with 2-pin MIL-style connector. Connector is fully potted and provided with integral molded boot to provide IP66 seal against moisture ingress. 7.1mm (0.28") diameter 304 stainless steel armor encapsulates a single twisted pair of conductors and shield.</p>
 <p>NOTE: Dielectric grease must be applied on the rubber boot connector to prevent moisture ingress.</p>	9334-211-XXXX-YYYY	<p><b>2-pin MIL Armored Cable Assembly</b>                      Similar to 9334-111 but without splash-proof boot and without IP66 rating; identical constraints on XXXX and YYYY ordering options.                       XXX.X = armor length in meters (example: 0035= 3.5 m)                      Min. armor length: 0.5m Max. armor length: 60m                      Must be ordered in 0.5m increments                       YYYY.Y = cable length in meters                      Min. cable length: 1.0 Max: 999.5m Must be ordered in 0.5 m increments;  <b>NOTE:</b> cable length must exceed armor length by at least 0.5 m.</p>
	8169-75-002-XXX	<p><b>2-wire Cable Assembly</b>                      Designed for installations where conduit will not be used to protect field wiring. Fitting mates directly to all 8200 elbows with 3/4" NPT reducers. Cable is 2-conductor (20 AWG) twisted, shielded pair in PVC jacket. Cable grip included for strain relief.                      Material: zinc-plated steel                       XXX= length in feet (example: 010=10 feet)                      Min. cable length: 1 foot (001) Max. cable length: 999 feet (999)</p>
	8201-001	<p><b>Conduit Union</b>                      Fits between ST5484E and 8200 conduit elbow when there is not enough room to rotate the elbow. Suitable for Class I, Div 1 (Grps A,B,C,D) and Class II, Div 1 (Grps E,F,G) hazardous areas.                      Material: zinc-plated steel</p>

	<b>7084-001</b>	<b>Flange Mount Adapter</b> Adapts 1/2" NPT mounting stud on ST5484E to 3-hole flat-base pattern. Hole pattern is three equally spaced 0.26" diameter holes on 1.5" diameter circle. Adapter is 2" diameter x 0.75" thick. Material: 303 stainless steel
	<b>7084-002</b>	<b>Flange Mount Adapter</b> Same as 7084-001 except center hole adapts 1/4" NPT stud on the 5484E.
	<b>7084-005</b>	<b>Flange Mount Adapter</b> Same as 7084-001 except center hole adapts 3/8 x 24 UNF stud on the 5484E.
	<b>8253-002</b>	<b>1/2" NPT to 1/4" NPT Reducer Bushing</b> Adapts 1/4" NPT stud on ST5484E (B=0) to 1/2" NPT mounting hole. Material: 303 stainless steel
	<b>93818-004</b>	<b>Cable Grip Strain Relief Fitting</b> Used primarily with 8978 cable assemblies where cable enters junction box. 3/4" NPT male thread to cable grip. Fits cable diameters from 0.156" to 0.25". Complete with sealing ring and locknut. Hot dip / mechanically galvanized finish. Suitable for NEMA 4 junction boxes.
	<b>93818-018</b>	<b>Cable Grip Strain Relief Fitting</b> Similar to 93818-004, but fits larger cable diameters from 0.4" to 0.5", such as customer-supplied cables used with terminal block versions of ST5484E (D = 2 or 3).

## OUTLINE DIAGRAMS

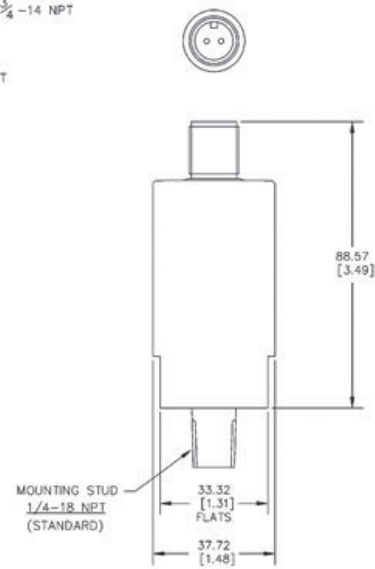
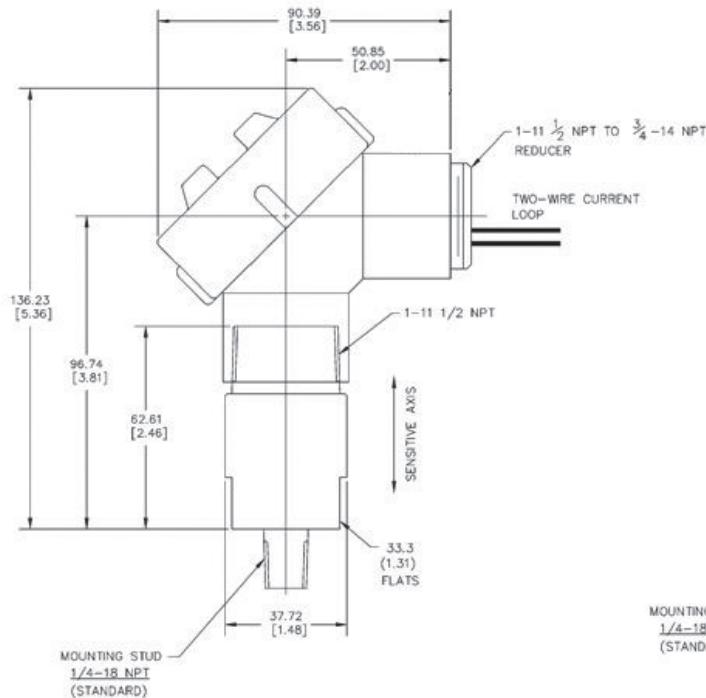

**Figure 1:** Outline dimensions of the ST5484E (all versions except MIL-Style Connector). Dimensions in mm [inches]. Optional\* 8200-001 conduit elbow shown installed.

**Figure 2:** Outline dimensions of the ST5484E-XXX-XX4-XX (MIL-Style Connector). Dimensions in mm [inches].

\* **NOTE:** 8200-AAA-IEC elbow is mandatory for ATEX/IECEX/INMETRO/KOSHA/EAC Ex d (flameproof) approved installations.

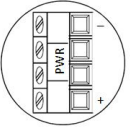

WIRING CONNECTIONS

Table 5 – Wiring Connection Legend		
Connector Type	Dynamic Signal Connections	Power Connections
MIL-C-5015	Not Available	24 V <sub>DC</sub> power may be connected to all ST5484E models without regard to polarity. Sensor uses IPT® independent polarity diode bridge circuit that will always orient voltage correctly inside sensor, regardless of polarity externally.  <b>NOTE:</b> Although the ST5484E allows polarity in either direction, installations using I.S. barriers will need to observe correct polarity at the barrier input side. However, the barrier output side (i.e., sensor connection) may be wired without regard to polarity.
2-wire flying leads	Not Available	
2-wire terminal block	Not Available	
4-wire flying leads	Red: Power + Blue: Power - White: Dynamic Signal - Black: Dynamic Signal +	
4-wire terminal block	 <p>NOTE: + AND – SYMBOLS ARE NOT ON LABEL</p>	

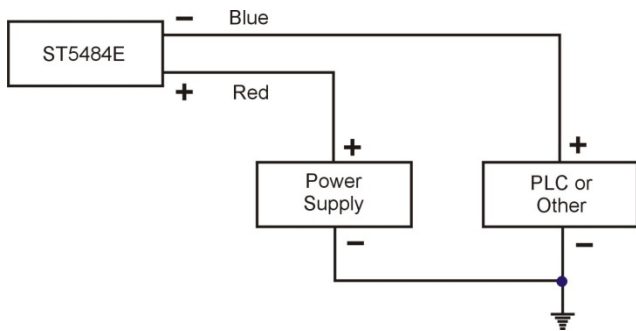

Figure 3: Typical installation for a single ST5484E seismic vibration transmitter.

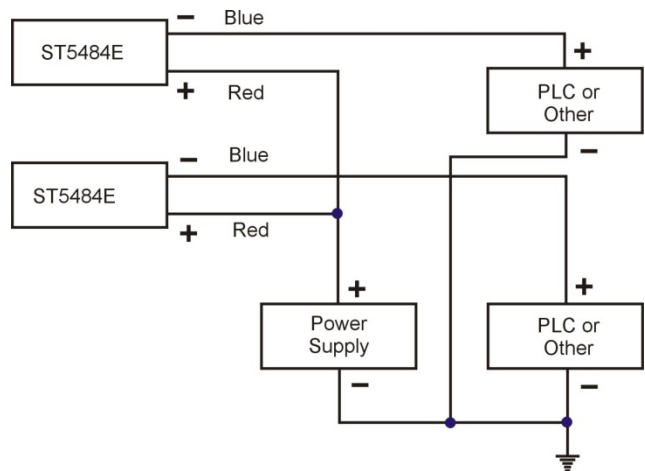

Figure 4: Typical installation for multiple ST5484E seismic vibration transmitters.

ADDITIONAL DOCUMENTATION

Description	Metrix Document Number
Manual	M9162
Installation Drawing – Hazardous Area with I.S. Barriers (CSA)	9426
Installation Drawing – Hazardous Area with I.S. Barriers (CENELEC)	9278
Installation Drawing – Div 2 / Zone 2	1086105

Trademarks used herein are the property of their respective owners.  
 Data and specifications subject to change without notice.  
 © 2014 Metrix Instrument Co., L.P.