

D04 CONN POINT	CONNECTION COMBINATION	
	CCWLE	CWLE
01	PROT	PROT
02	PROT ST-M1	PROT ST-M1
03	FN-M1	FN-M1
04	FN-A1	ST-A1
05	ST-A1	FN-A1

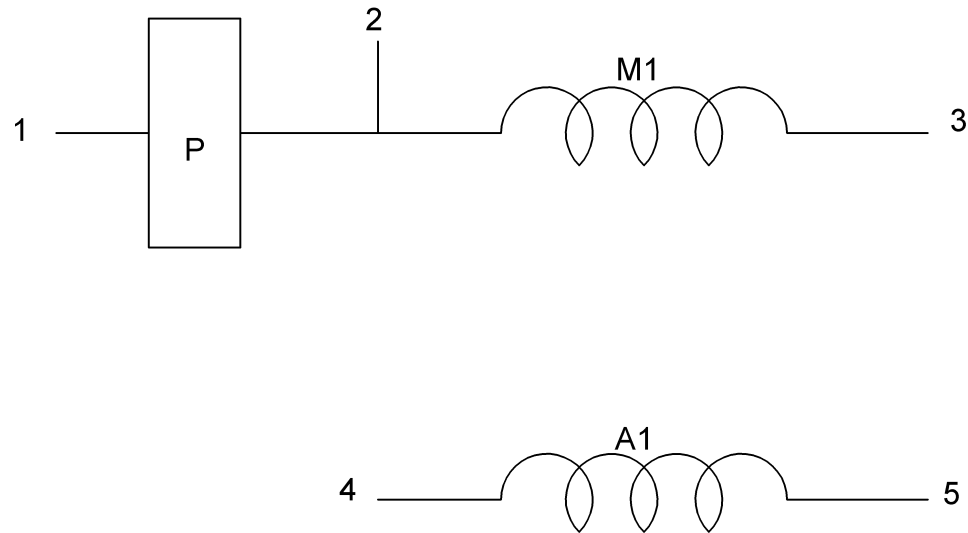

REVISION DESCRIPTION FOR: C8396-01		SCALE	NONE	UNITS	IN	TITLE		NIDEC MOTOR CORPORATION
UPDATED BACKGROUND TO NIDEC		TOLERANCES ON DIMENSIONS (UNLESS OTHERWISE SPECIFIED)				NAMEPLATE ASM		
MATERIAL:		INCHES		mm		ISSUED BY	APPROVED BY	REVISION DATE
		.XX = ± .01				A. SANCHEZ	J.I. SALAZAR	20-SEP-13
		.XXX = ± .005				CODE	DWG NO.	REV
		ANGLES X° = ±1°				D04	291413	A
								SHEET NUMBER
								1 OF 1
								DWG SIZE
								A



NIDEC CONFIDENTIAL  
NIDEC MOTOR CORPORATION 30-Sep-13  
NMCA (MAR-2011)

MUST BE COMPLIANT TO RoHS DIRECTIVE EU 2002/95/IEC  
AND REGULATION EC 1907/2006 (REACH) AS AMENDED

SOLIDEDGE