

EFFECTIVE:
06-JUL-11

HORIZONTAL MOTORS

TEFC - CLOSE COUPLED PUMP

FRAME: 143JP
BASIC TYPE: UT-1

PRINT:
07-1849

SUPERSEDES:
27-OCT-95

SHEET:
1 OF 1

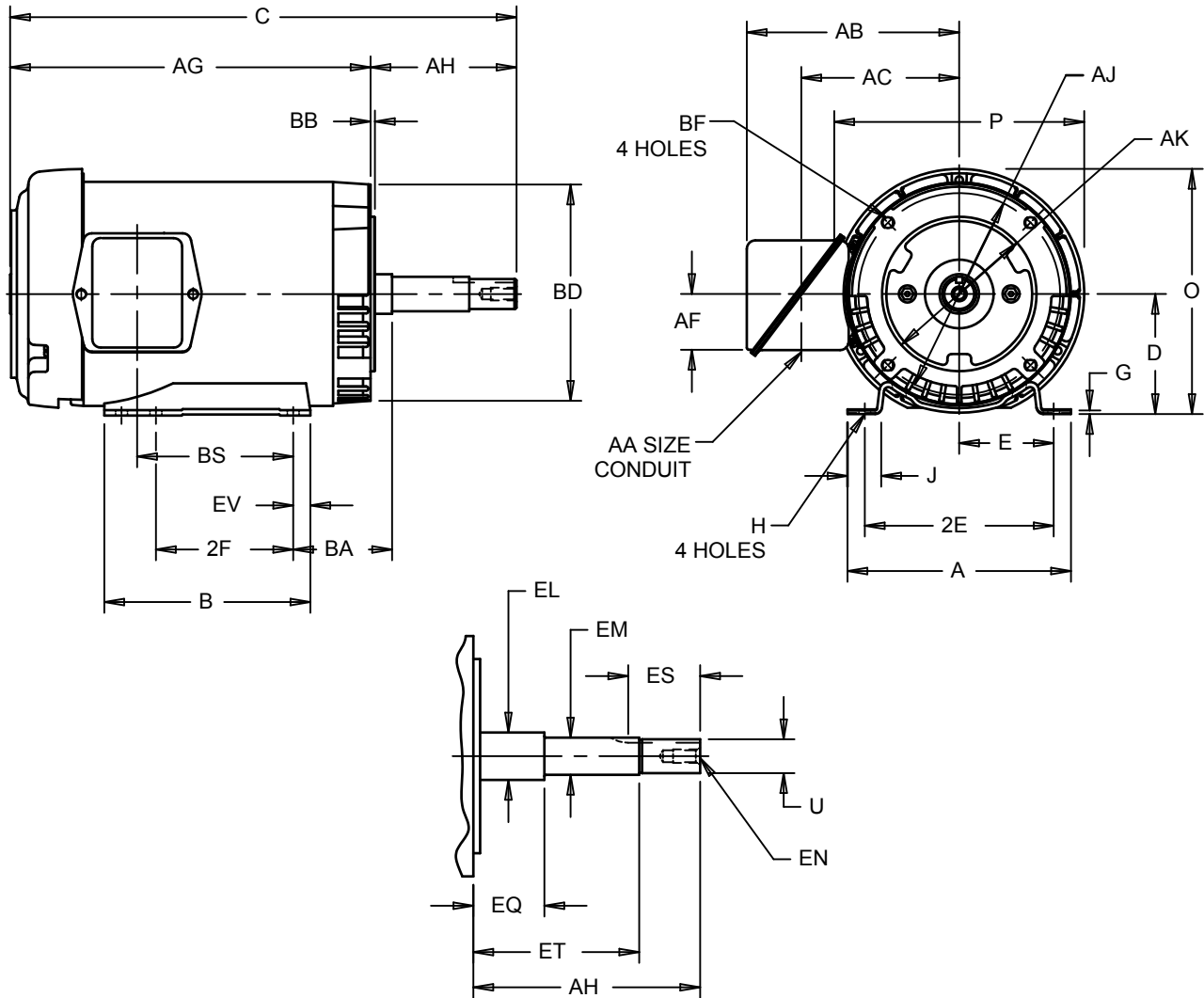

ALL DIMENSIONS ARE IN INCHES AND MILLIMETERS

UNITS	A	B	C	D	E	2E	2F	G	H	J	O	P	U
IN	6.50	6.00	17.31	$-.06$	2.75	$\pm.03$	$\pm.03$.13	$+.05$.88	7.19	7.28	$-.0005$
MM	165	152	440	89	70	5.50	4.00	3	.34	22	182	185	22.225

UNITS	AA	AB	AC	AF	AG	AH	AJ	AK	BA	BB	BD	BF
IN	.75	6.09	4.50	1.63	10.00	7.31	5.88	$-.003$	4.50	.13	6.50	3/8-16 X .75
MM		155	114	41	254	186	149	114.30	114	3	165	

UNITS	BS	EL	EM	EN	EQ	ES	ET	EV	SQ
IN	3.22	$-.002$	$-.0005$	3/8-16 X .75	1.563	MIN 1.75	5.31	.50	KEY .188
MM	82	29.36	25.400		39.70	44	135	13	4.76

1: TOLERANCES SHOWN ARE IN INCHES ONLY.

07-1849/A

Nidec Motor Corporation
St. Louis, Missouri

INFORMATION DISCLOSED ON THIS DOCUMENT
IS CONSIDERED PROPRIETARY AND SHALL NOT BE
REPRODUCED OR DISCLOSED WITHOUT WRITTEN
CONSENT OF NIDEC MOTOR CORPORATION



ISSUED BY
A. HINGANKAR
APPROVED BY
R. KING

IHP_DP_NMCA (MAR-2011) SOLIDEDGE