

EFFECTIVE:
08-DEC-14

DIMENSION PRINT

PRINT:
07-2509

SUPERSEDES:
02-JAN-03

OPEN
FRAME: 56C
BASIC TYPE: DF

SHEET:
1 OF 1

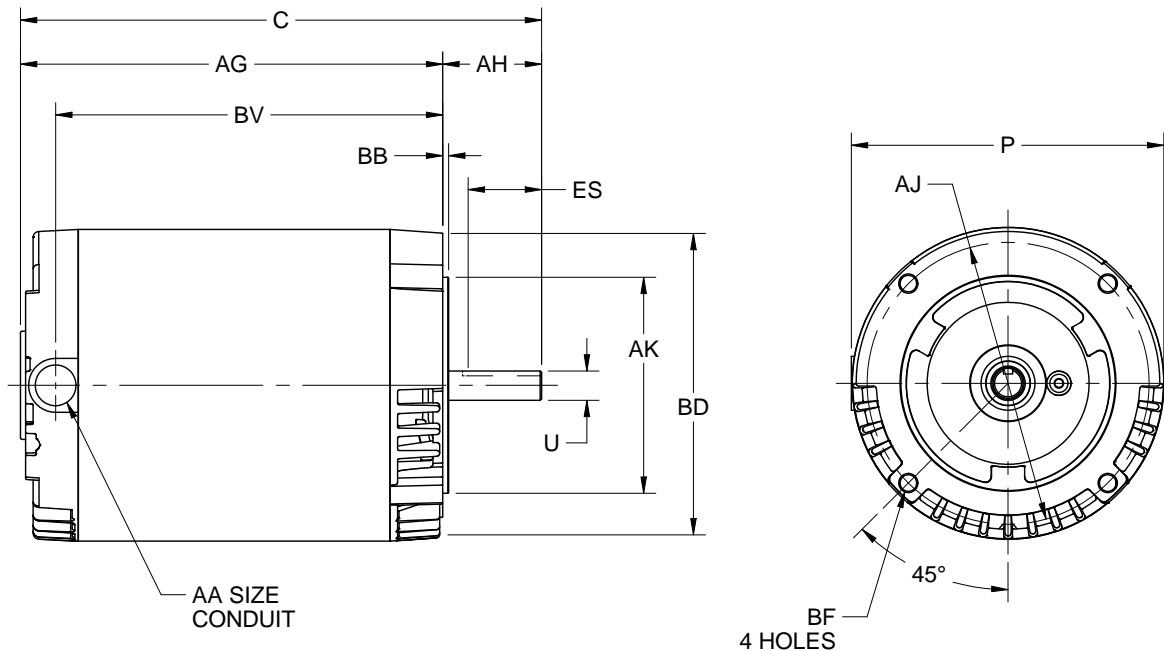

	C	P ⁴	U -.0005	AA	AG	AH	AJ	AK -.003
IN	12.88	6.50	.6250	1/2 NPT	10.81	2.06	5.875	4.500
MM	327	165	15.875		275	52	149.23	114.30

	BB MIN	BD MAX	BF ³	BV	ES MIN	SQ KEY
IN	.13	6.50	3/8-16 X .75	10.06	1.44	.188
MM	25	165		256	37	4.78

TOLERANCES	
FACE RUNOUT	.004 T.I.R.
PERMISSIBLE ECCENTRICITY OF MOUNTING RABBET	.004 T.I.R.
PERMISSIBLE SHAFT RUNOUT	.002 T.I.R.

1. DIMENSIONS MAY VARY .25" DUE TO CASTING AND/OR FABRICATION VARIATIONS.
2. ALL TAPPED HOLES ARE UNIFIED NATIONAL COARSE, RIGHT HAND THREAD.
3. TAP SIZE AND BOLT PENETRATION ALLOWANCE.

4. LARGEST MOTOR WIDTH.
5. TOLERANCES ARE ALL IN INCHES.
6. FRAME REFERENCE: 8.500/56

07-2509/A

Nidec Motor Corporation
St. Louis, Missouri

INFORMATION DISCLOSED ON THIS DOCUMENT IS CONSIDERED PROPRIETARY AND SHALL NOT BE REPRODUCED OR DISCLOSED WITHOUT WRITTEN CONSENT OF NIDEC MOTOR CORPORATION



ISSUED BY
R. KING
APPROVED BY
J. HAGENE

IHP_DP_NMCA (MAR-2011) SOLIDEDGE