

EFFECTIVE:
11-APR-12

HORIZONTAL MOTORS

PRINT:
07-2513

SUPERSEDES:
01-MAY-03

OPEN
FRAME: 56C
BASIC TYPE: D

SHEET:
1 OF 1

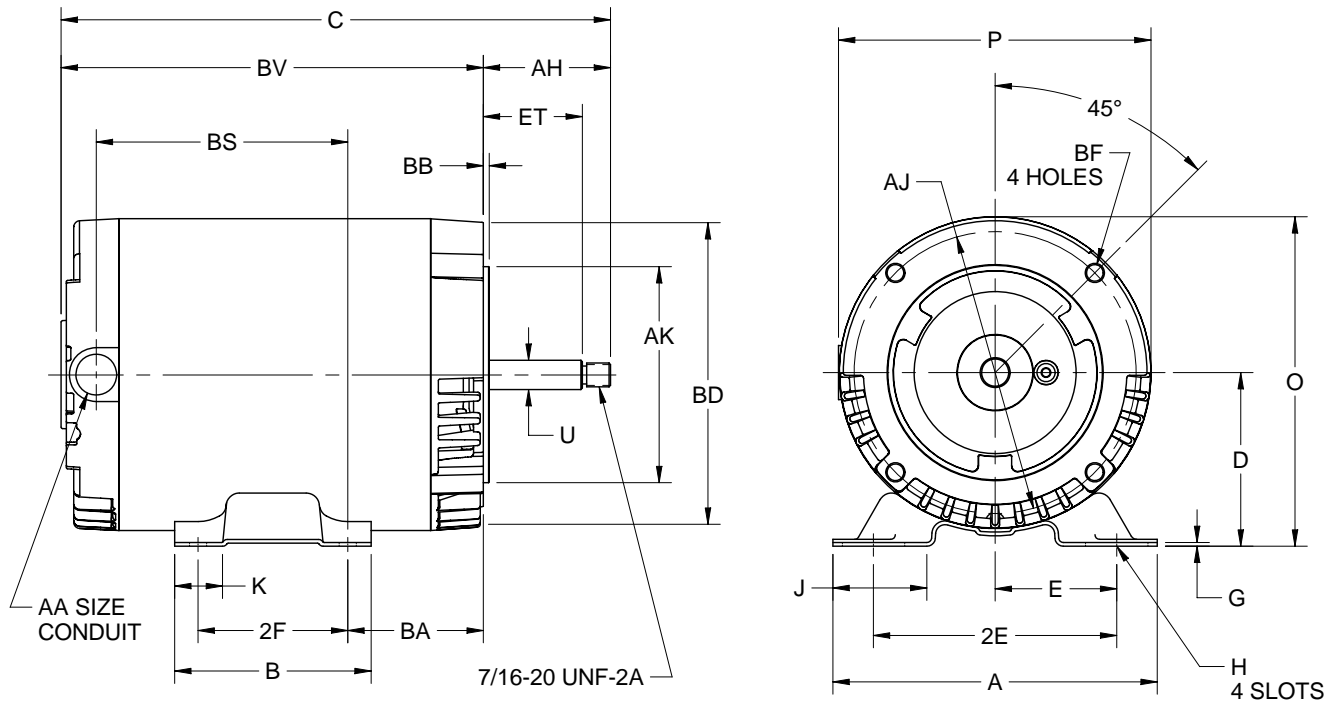

	A	B	C	D	E	2E	2F	G	H
IN	6.50	4.00	12.38	$3.50_{-.03}$	2.44	4.875	3.00	.104	.344 X 1.25
MM	165	102	314	89	62	124	76	2.64	

	J	K	O	P ⁴	U	AA	AH	AJ	AK
IN	2.00	1.00	6.75	6.50	$.6250_{-.0005}$	1/2 NPT	2.56	5.875	4.500
MM	51	25	171	165	15.875		65	149.23	114.30

	BA	BB MIN	BD MAX	BF ³	BS	BV	ET
IN	2.56	.13	6.50	3/8-16 X .75	6.50	9.06	$1.875_{\pm.015}$
MM	65	3	165		165	230	47.62

TOLERANCES	
FACE RUNOUT	.004 T.I.R.
PERMISSIBLE ECCENTRICITY OF MOUNTING RABBET	.004 T.I.R.
PERMISSIBLE SHAFT RUNOUT	.002 T.I.R.

1. DIMENSIONS MAY VARY .25" DUE TO CASTING AND/OR FABRICATION VARIATIONS.
2. ALL TAPPED HOLES ARE UNIFIED NATIONAL COARSE, RIGHT HAND THREAD.
3. TAP SIZE AND BOLT PENETRATION ALLOWANCE.

4. LARGEST MOTOR WIDTH.
5. TOLERANCES ARE ALL IN INCHES.
6. FRAME REFERENCE: 7.500/56

07-2513/A

Nidec Motor Corporation
St. Louis, Missouri

INFORMATION DISCLOSED ON THIS DOCUMENT IS CONSIDERED PROPRIETARY AND SHALL NOT BE REPRODUCED OR DISCLOSED WITHOUT WRITTEN CONSENT OF NIDEC MOTOR CORPORATION



ISSUED BY
K. FRIEDMAN
APPROVED BY
J. HAGENE

IHP_DP_NMCA (MAR-2011) SOLIDEDGE