

EFFECTIVE:  
**26-MAY-11**

**HORIZONTAL MOTORS**  
ODP - CLOSE COUPLED PUMP  
FRAME: A254JM  
BASIC TYPE: FD-4

PRINT:  
**07-2573**

SUPERSEDES:  
**24-FEB-03**

SHEET:  
**1 OF 1**

STANDARD F-1 ASSEMBLY

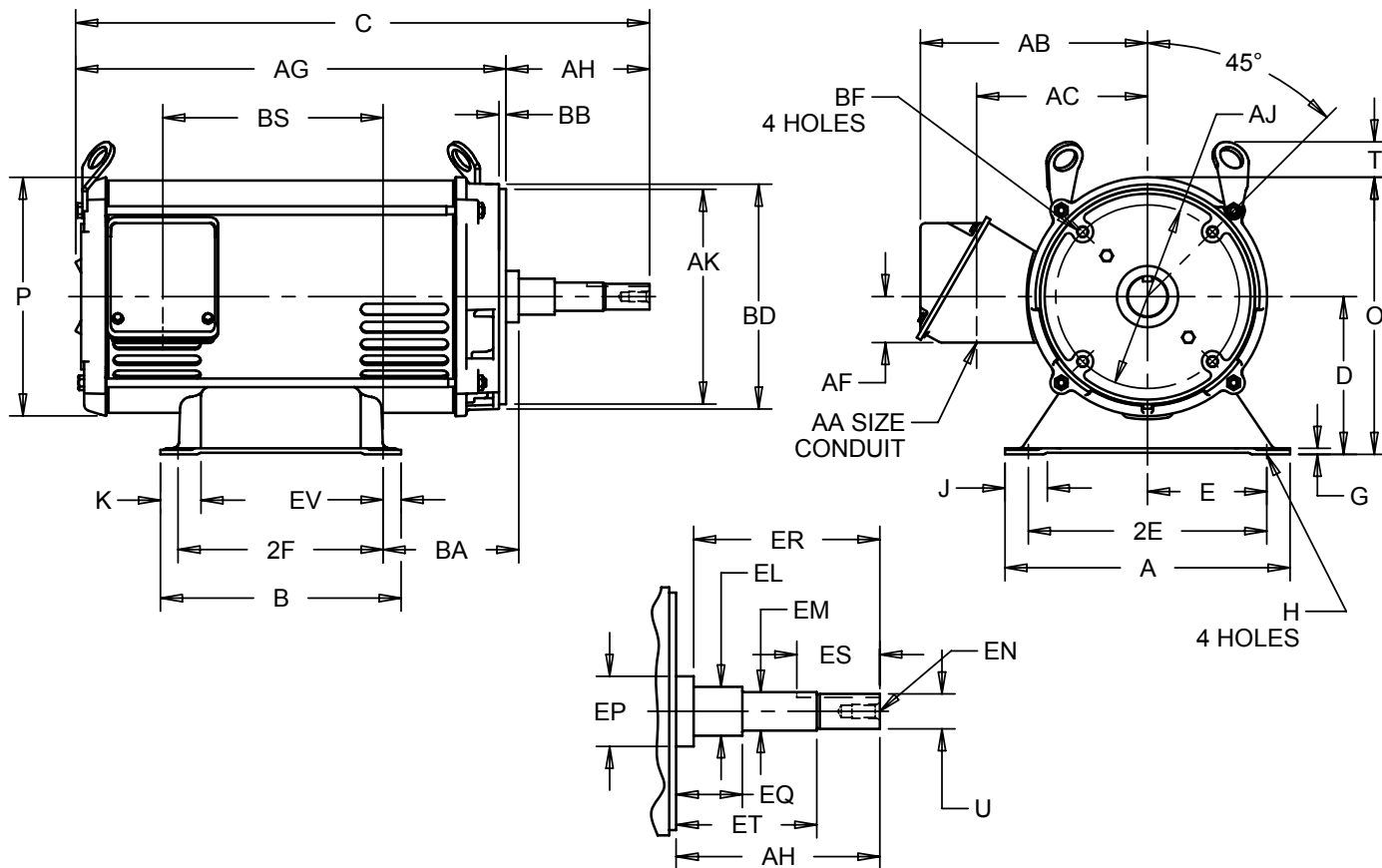

ALL DIMENSIONS ARE IN INCHES AND MILLIMETERS

UNITS	A	B	C	D -.06	E	2E ±.03	2F ±.03	G	H +.05	J	K	O	P <sup>2</sup>	T
IN	11.25	9.50	22.31	6.25	5.00	10.00	8.25	.19	.56	1.44	1.38	11.00	9.44	1.50
MM	286	241	567	159	127	254	210	5	14	37	35	279	240	38

UNITS	U -.0005	AA	AB	AC	AF	AG	AH ±.031	AJ	AK -.003	BA	BB ±.031	BD MAX	BF <sup>3</sup>
IN	1.2495	1.25	8.81	6.78	1.81	16.88	5.250	7.250	8.500	4.75	.281	10.00	1/2-13 X .75
MM	31.737		224	172	46	429	133.35	184.15	215.90	121	7.14	254	

UNITS	BS	EL -.002	EM -.0005	EN <sup>3</sup>	EP MIN	EQ ±.015	ER MIN	ES MIN	ET ±.015	EV	SQ KEY
IN	9.18	1.750	1.3750	1/2-13 X 1.00	1.75	.625	5.25	2.53	3.000	.63	.250
MM	233	44.45	34.925		44	15.88	133	64	76.20	16	6.53

- 1: ALL ROUGH DIMENSIONS MAY VARY BY .25" DUE TO CASTING AND/OR FABRICATION VARIATIONS.
- 2: LARGEST MOTOR WIDTH.
- 3: TAP SIZE AND BOLT PENETRATION ALLOWANCE.
- 4: ALL TAPPED HOLES ARE UNIFIED NATIONAL COARSE, RIGHT HAND THREAD.
- 5: CONDUIT BOX MAY BE LOCATED ON EITHER SIDE AND CONDUIT OPENING MAY BE LOCATED IN STEPS OF 90° REGARDLESS OF LOCATION. STANDARD AS SHOWN WITH CONDUIT OPENING DOWN.
- 6: TOLERANCES SHOWN ARE IN INCHES ONLY.
- 7: FRAME REFERENCE: 254/14.024

TOLERANCES	
FACE RUNOUT	.004 T.I.R.
PERMISSIBLE ECCENTRICITY OF MOUNTING RABBET	.004 T.I.R.
PERMISSIBLE SHAFT RUNOUT	.002 T.I.R.

07-2573/A

**Nidec Motor Corporation**  
St. Louis, Missouri

INFORMATION DISCLOSED ON THIS DOCUMENT IS CONSIDERED PROPRIETARY AND SHALL NOT BE REPRODUCED OR DISCLOSED WITHOUT WRITTEN CONSENT OF NIDEC MOTOR CORPORATION



ISSUED BY  
**P. INGALE**  
APPROVED BY  
**R. KING**

IHP\_DP\_NMCA (MAR-2011) SOLIDEDGE