

EFFECTIVE:
26-MAY-11

HORIZONTAL MOTORS

ODP - CLOSE COUPLED PUMP
FRAME: 182, 184JP
BASIC TYPE: DM-1

PRINT:
07-2577

SUPERSEDES:
03-APR-03

SHEET:
1 OF 1

STANDARD F-1 ASSEMBLY

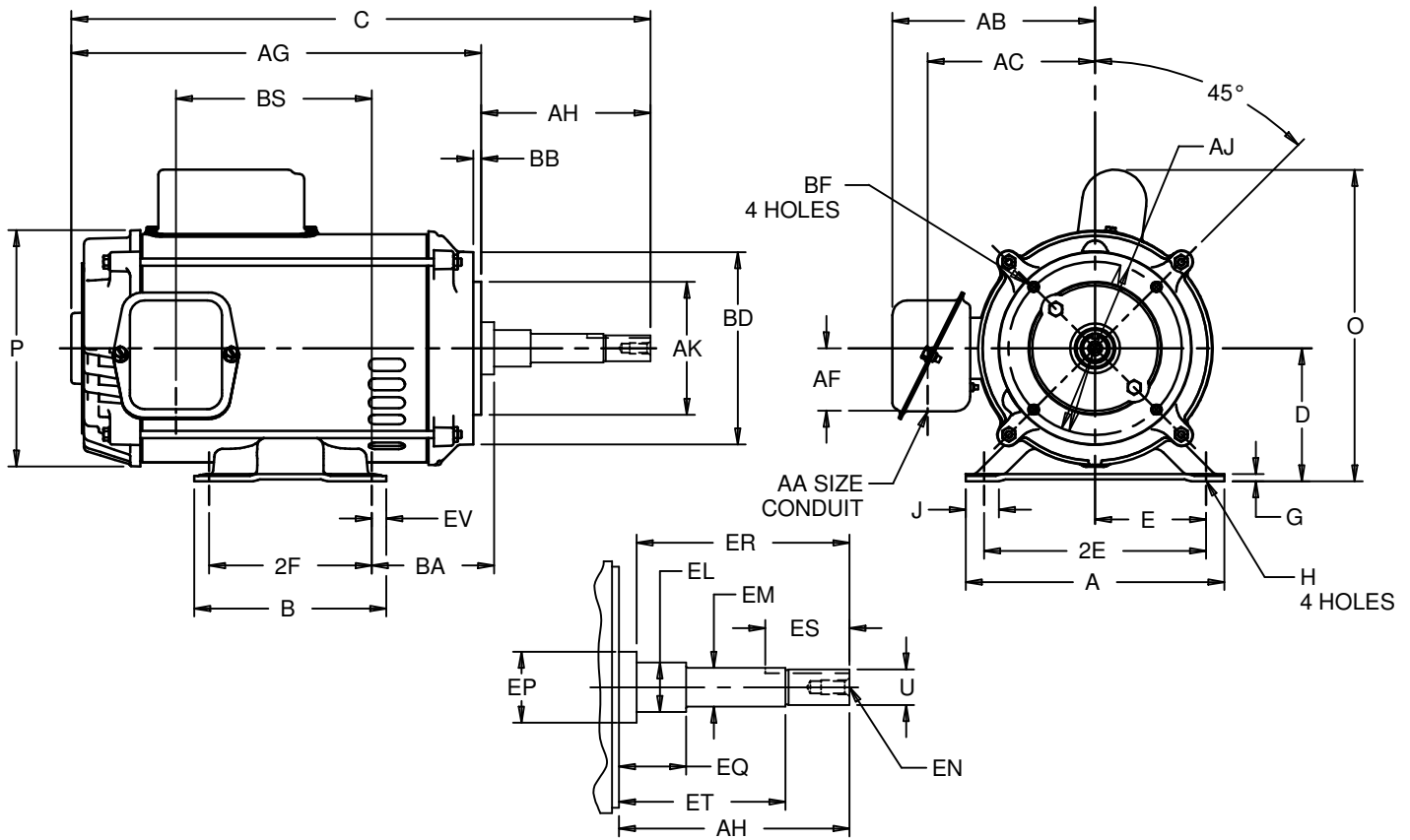

ALL DIMENSIONS ARE IN INCHES AND MILLIMETERS

BASIC SIZE	UNITS	A	B	C	D -.06	E	2E ±.03	G	H +.05	J	O	P ²	U -.0005	AA
180	IN	8.75	6.50	20.56	4.50	3.75	7.50	.19	.44	1.00	10.53	7.75	.8745	1.12
	MM	222	165	522	114	95	191	5	11	25	267	197	22.212	

BASIC SIZE	UNITS	AB	AC	AF	AG	AH ±.031	AJ	AK -.003	BA	BB ±.031	BD MAX	BF ³	BS
180	IN	6.83	5.63	2.13	13.19	4.250	5.875	4.500	3.50	.156	6.50	3/8-16 X .63	6.09
	MM	173	143	54	335	107.95	149.23	114.30	89	3.96	165		155

BASIC SIZE	UNITS	EL -.002	EM -.0005	EN ³	EP MIN	EQ ±.015	ER MIN	ES MIN	ET ±.015	EV	SQ KEY
180	IN	1.250	1.0000	3/8-16 X .75	1.25	1.562	7.31	1.66	5.938	.50	.188
	MM	31.75	25.400		32	39.67	186	42	150.82	13	4.78

SIZE	UNITS	2F ±.03
182	IN	4.50
	MM	114
184	IN	5.50
	MM	140

- 1: ALL ROUGH DIMENSIONS MAY VARY BY .25" DUE TO CASTING AND/OR FABRICATION VARIATIONS.
- 2: LARGEST MOTOR WIDTH.
- 3: TAP SIZE AND BOLT PENETRATION ALLOWANCE.
- 4: ALL TAPPED HOLES ARE UNIFIED NATIONAL COARSE, RIGHT HAND THREAD.
- 5: CONDUIT BOX MAY BE LOCATED ON EITHER SIDE AND CONDUIT OPENING MAY BE LOCATED IN STEPS OF 90° REGARDLESS OF LOCATION. STANDARD AS SHOWN WITH CONDUIT OPENING DOWN.
- 6: TOLERANCES SHOWN ARE IN INCHES ONLY.
- 7: FRAME REFERENCE: 9.500

TOLERANCES	
FACE RUNOUT	.004 T.I.R.
PERMISSIBLE ECCENTRICITY OF MOUNTING RABBET	.004 T.I.R.
PERMISSIBLE SHAFT RUNOUT	.002 T.I.R.

07-2577/A

Nidec Motor Corporation
St. Louis, Missouri

INFORMATION DISCLOSED ON THIS DOCUMENT IS CONSIDERED PROPRIETARY AND SHALL NOT BE REPRODUCED OR DISCLOSED WITHOUT WRITTEN CONSENT OF NIDEC MOTOR CORPORATION



ISSUED BY
V. PAWAR
APPROVED BY
R. KING

IHP_DP_NMCA (MAR-2011) SOLIDEDGE