

EFFECTIVE:  
16-MAR-10

# HORIZONTAL MOTORS

PRINT:  
07-2690

SUPERSEDES:  
14-AUG-09

TEFC  
FRAME: 5000S, ML  
TYPE: J

SHEET:  
1 OF 1

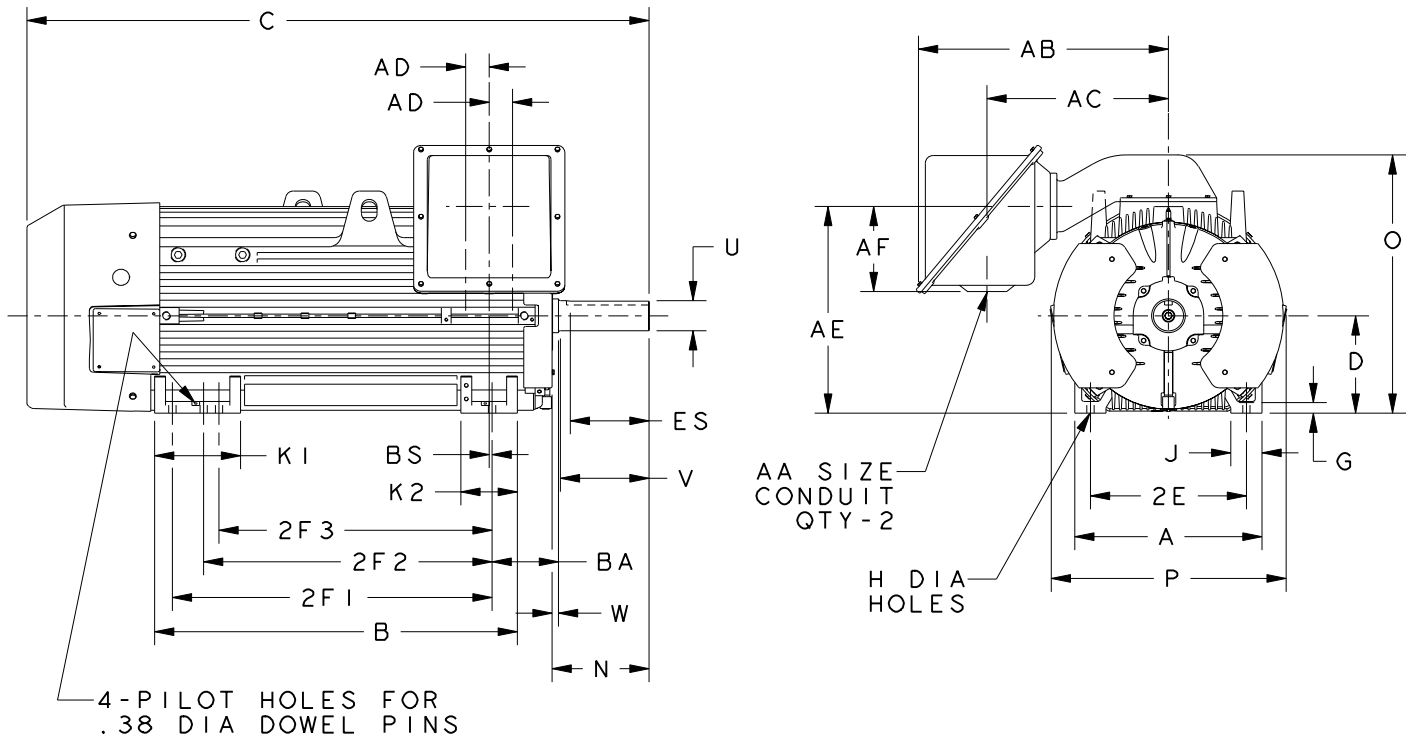

ALL DIMENSIONS ARE IN INCHES

A	D	2E	G	H <sup>4</sup> +.05	J	K1	K2	O	P <sup>2</sup>
24.00	12.50	±.03	1.38	.94	4.00	11.00	7.25	33.13	30.13

W	AB	AC	AD	AE	AF	BA	BS
.63	32.06	23.25	3.00	26.50	10.94	8.50	.38

FRAME	N	U	V	ES	SO
		-.001	MIN	MIN	KEY
5000S	6.38	2.875	5.50	4.00	.750
5000ML	12.25	3.875	11.38	10.00	1.000

FRAME	B	C	2F1	2F2	2F3
			±.03	±.03	±.03
5008S	31.50	58.88	25.00	22.00	20.00
5008ML	31.50	64.75	25.00	22.00	20.00
5010S	38.50	65.88	32.00	28.00	N/A
5010ML	38.50	71.75	32.00	28.00	N/A
5012S	46.50	73.88	40.00	36.00	N/A
5012ML	46.50	79.75	40.00	36.00	N/A

AA
3 NPT
3 1/2 NPT
4 NPT

- 1: DIMENSIONS MAY VARY .25" DUE TO CASTING AND/OR FABRICATION VARIATIONS.
- 2: LARGEST MOTOR WIDTH.
- 3: CONDUIT OPENING MAY BE ROTATED IN IN STEPS OF 90 DEGREES.  
STANDARD AS SHOWN WITH CONDUIT OPENING DOWN.
- 4: QTY-8 HOLES ON 5008 FRAME AND QTY-6 HOLES ON ALL OTHERS.