

EFFECTIVE:
31-MAY-11

SUPERSEDES:
10-OCT-08

HORIZONTAL MOTORS
AUTOMOTIVE DUTY
FRAME: 400US
BASIC TYPE: JAD, JDE

PRINT:
07-2705

SHEET:
1 OF 1

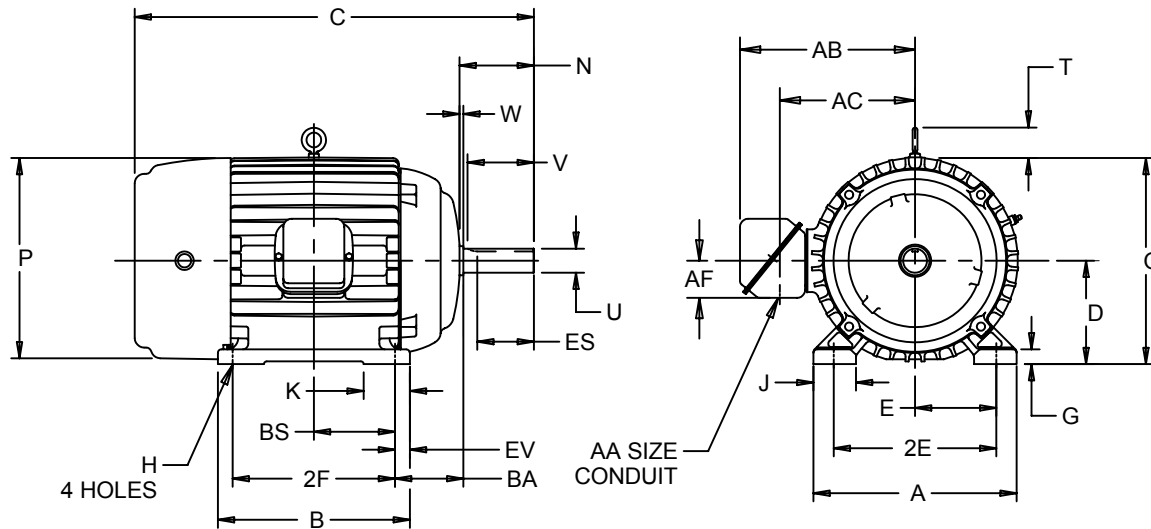

ALL DIMENSIONS ARE IN INCHES AND MILLIMETERS

UNITS	A	B	C	D -.06	E	2E ±.03	G	H +.05	J	K	N	O	P ²
IN	19.75	16.75	34.59	10.00	8.00	16.00	1.38	.81	3.75	5.00	4.75	20.47	21.59
MM	502	425	879	254	203	406	35	21	95	127	121	520	548

UNITS	T	U -.001	V MIN	W	AA	AB	AC	AF	BA	BS	ES MIN	EV	SQ KEY
IN	2.94	2.125	4.00	.50	2 1/2 NPT	17.69	13.44	4.19	6.63	6.88	2.88	1.50	.500
MM	75	53.98	102	13		449	341	106	168	175	73	38	12.70

FRAME	UNITS	2F ±.03
404US	IN	12.25
	MM	311
405US	IN	13.75
	MM	349

- 1: ALL ROUGH CASTING DIMENSIONS MAY VARY BY .25" DUE TO CASTING AND/OR FABRICATION VARIATIONS.
- 2: LARGEST MOTOR WIDTH.
- 3: TOLERANCES SHOWN ARE IN INCHES ONLY.
- 4: STANDARD ASSEMBLY POSITION F-1 IS SHOWN F-2 IS PROVIDED WHEN SPECIFIED. CONDUIT OPENINGS MAY BE LOCATED IN STEPS OF 90° REGARDLESS OF LOCATION. STANDARD AS SHOWN WITH CONDUIT OPENING DOWN.

07-2705/A

Nidec Motor Corporation
St. Louis, Missouri

INFORMATION DISCLOSED ON THIS DOCUMENT IS CONSIDERED PROPRIETARY AND SHALL NOT BE REPRODUCED OR DISCLOSED WITHOUT WRITTEN CONSENT OF NIDEC MOTOR CORPORATION



ISSUED BY
A. HINGANKAR
APPROVED BY
R. KING

IHP_DP_NMCA (MAR-2011) SOLIDEDGE