

EFFECTIVE:
06-APR-15
SUPERSEDES:
03-JUN-11

DIMENSION PRINT
HOSTILE DUTY
FRAME: 364, 365T, TS
BASIC TYPE: CT

PRINT:
07-2726
SHEET:
1 OF 1

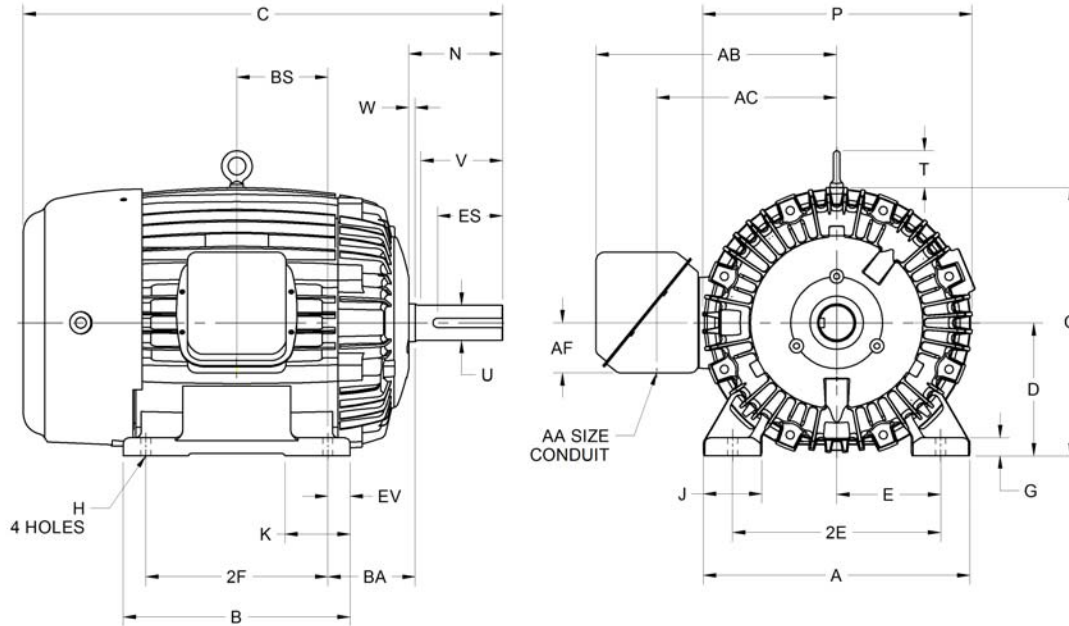

ALL DIMENSIONS ARE IN INCHES AND MILLIMETERS

UNITS	A	B	D -.06	E	2E ±.03	G	H +.05	J	K	O	P ²
IN	17.94	15.25	9.00	7.00	14.00	1.22	.66	3.94	4.38	18.09	18.13
MM	456	387	229	178	356	31	17	100	111	460	460

UNITS	T	W	AA	AB	AC	AF	BA	BS	EV
IN	2.50	.44	3.00	16.22	12.13	3.38	5.88	6.13	1.50
MM	64	11		412	308	86	149	156	38

FRAME	UNITS	C	N	U -.001	V MIN	ES MIN	SQ KEY
364, 365T	IN	32.25	6.31	2.375	5.62	4.28	.625
	MM	819	160	60.33	143	109	15.88
364, 365TS	IN	30.13	4.19	1.875	3.50	2.03	.500
	MM	765	106	47.63	89	52	12.70

FRAME	UNITS	2F ±.03
364T, TS	IN	11.25
	MM	286
365T, TS	IN	12.25
	MM	311

1. DIMENSIONS MAY VARY .25" DUE TO CASTING AND/OR FABRICATION VARIATIONS
2. LARGEST MOTOR WIDTH
3. STANDARD ASSEMBLY POSITION F-1 IS SHOWN. F-2 IS PROVIDED WHEN SPECIFIED. CONDUIT OPENINGS MAY BE LOCATED IN STEPS OF 90° REGARDLESS OF THE LOCATION
4. TOLERANCES ARE SHOWN IN INCHES ONLY

07-2726/B

Nidec Motor Corporation
St. Louis, Missouri

INFORMATION DISCLOSED ON THIS DOCUMENT IS CONSIDERED PROPRIETARY AND SHALL NOT BE REPRODUCED OR DISCLOSED WITHOUT WRITTEN CONSENT OF NIDEC MOTOR CORPORATION



ISSUED BY
R. TIMMERMANN
APPROVED BY
M. CULLEN

IHP_DP_NMCA (MAR-2011) SOLIDEDGE