

EFFECTIVE:
09-MAY-14

DIMENSION PRINT

PRINT:
07-2770

SUPERSEDES:
07-JUN-11

FRAME: 280T, TS
BASIC TYPE: LC, NC

SHEET:
1 OF 1

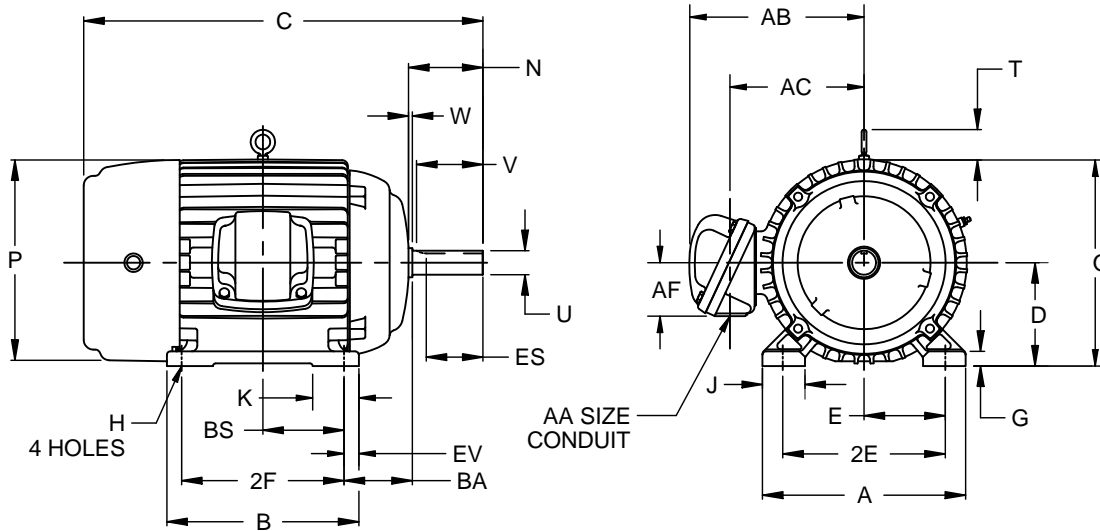

ALL DIMENSIONS ARE IN INCHES AND MILLIMETERS

UNITS	A	B	D -.06	E	2E ±.03	G	H +.05	J	O	P ²
IN	14.00	13.00	7.00	5.50	11.00	1.00	.53	2.88	14.16	14.31
MM	356	330	178	140	279	25	13	73	360	363

UNITS	T	AA	AB	AC	AF	BA	BS	EV	W
IN	2.03	2 NPT	13.19	9.69	3.88	4.75	5.50	1.00	.38
MM	52		335	246	99	121	140	25	10

FRAME	UNITS	C	N	U -.001	V MIN	ES MIN	SQ KEY
280T	IN	27.66	5.00	1.875	4.38	3.28	.500
	MM	703	127	47.63	111	83	12.70
280TS	IN	26.28	3.63	1.625	3.00	1.91	.375
	MM	668	92	41.28	76	49	9.53

FRAME	UNITS	2F ±.03
284T, TS	IN	9.50
	MM	241
286T, TS	IN	11.00
	MM	279

- ALL ROUGH CASTING DIMENSIONS MAY VARY BY .25" DUE TO CASTING AND /OR FABRICATION VARIATIONS.
- LARGEST MOTOR WIDTH.
- TOLERANCES SHOWN ARE IN INCHES ONLY.
- STANDARD ASSEMBLY POSITION F-1 IS SHOWN F-2 IS PROVIDED WHEN SPECIFIED. CONDUIT OPENINGS MAY BE LOCATED IN STEPS OF 90° REGARDLESS OF LOCATION. STANDARD AS SHOWN WITH CONDUIT OPENING DOWN

07-2770/C

Nidec Motor Corporation
St. Louis, Missouri

INFORMATION DISCLOSED ON THIS DOCUMENT IS CONSIDERED PROPRIETARY AND SHALL NOT BE REPRODUCED OR DISCLOSED WITHOUT WRITTEN CONSENT OF NIDEC MOTOR CORPORATION



ISSUED BY
S. GARCIA
APPROVED BY
R. TIMMERMAN

IHP_DP_NMCA (MAR-2011) SOLIDEDGE