

EFFECTIVE:
12-SEP-12

HORIZONTAL MOTORS WITH OVERSIZED OUTLET BOX

PRINT:
07-2835-02

SUPERSEDES:
NEW

FRAME: 254, 256T
BASIC TYPE: LC,NC

SHEET:
1 OF 1

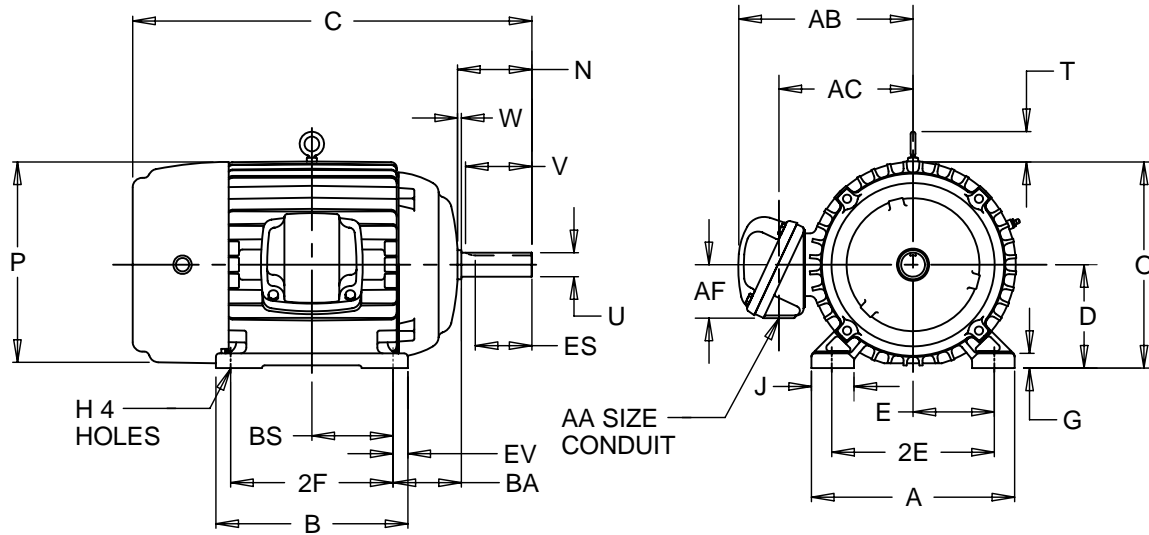

ALL DIMENSIONS ARE IN INCHES AND MILLIMETERS

UNITS	A	B	C	D -.06	E	2E ±.03	G	H +.05	J	N
IN	12.13	12.00	25.00	6.25	5.00	10.00	.88	.53	2.25	4.38
MM	308	305	635	159	127	254	22	14	57	111

UNITS	O	P ²	T	U -.001	V MIN	W	AA	AB	AC	AF	BA
IN	12.91	13.31	2.03	1.625	3.75	.38	2 NPT	12.56	9.06	3.88	4.25
MM	328	338	52	41.28	95	10		319	230	99	108

UNITS	BS	ES MIN	EV	SQ KEY
IN	5.00	2.91	1.00	.375
MM	127	74	25	10

FRAME	UNITS	2F ±.03
254T	IN	8.25
	MM	210
256T	IN	10.00
	MM	254

1: ALL ROUGH CASTING DIMENSIONS MAY VARY BY .25" DUE TO CASTING AND/OR FABRICATION VARIATIONS.
2: LARGEST MOTOR WIDTH.
3: TOLERANCES SHOWN ARE IN INCHES ONLY.

4: STANDARD ASSEMBLY POSITION F-1 IS SHOWN F-2 IS PROVIDED WHEN SPECIFIED. CONDUIT OPENINGS MAY BE LOCATED IN STEPS OF 90 DEGREES REGARDLESS OF LOCATION. STANDARD AS SHOWN WITH CONDUIT OPENING DOWN.

07-2835/A

Nidec Motor Corporation
St. Louis, Missouri

INFORMATION DISCLOSED ON THIS DOCUMENT IS CONSIDERED PROPRIETARY AND SHALL NOT BE REPRODUCED OR DISCLOSED WITHOUT WRITTEN CONSENT OF NIDEC MOTOR CORPORATION



ISSUED BY
R. KING
APPROVED BY
J. O'BRIEN

IHP_DP_NMCA (MAR-2011) SOLIDEDGE