

EFFECTIVE:  
09-MAY-16

# DIMENSION PRINT WITH NEMA "C" BRACKET

PRINT:  
07-2864

SUPERSEDES:  
20-JUN-11

FRAME: 250TC  
BASIC TYPE: LF, NF

SHEET:  
1 OF 1

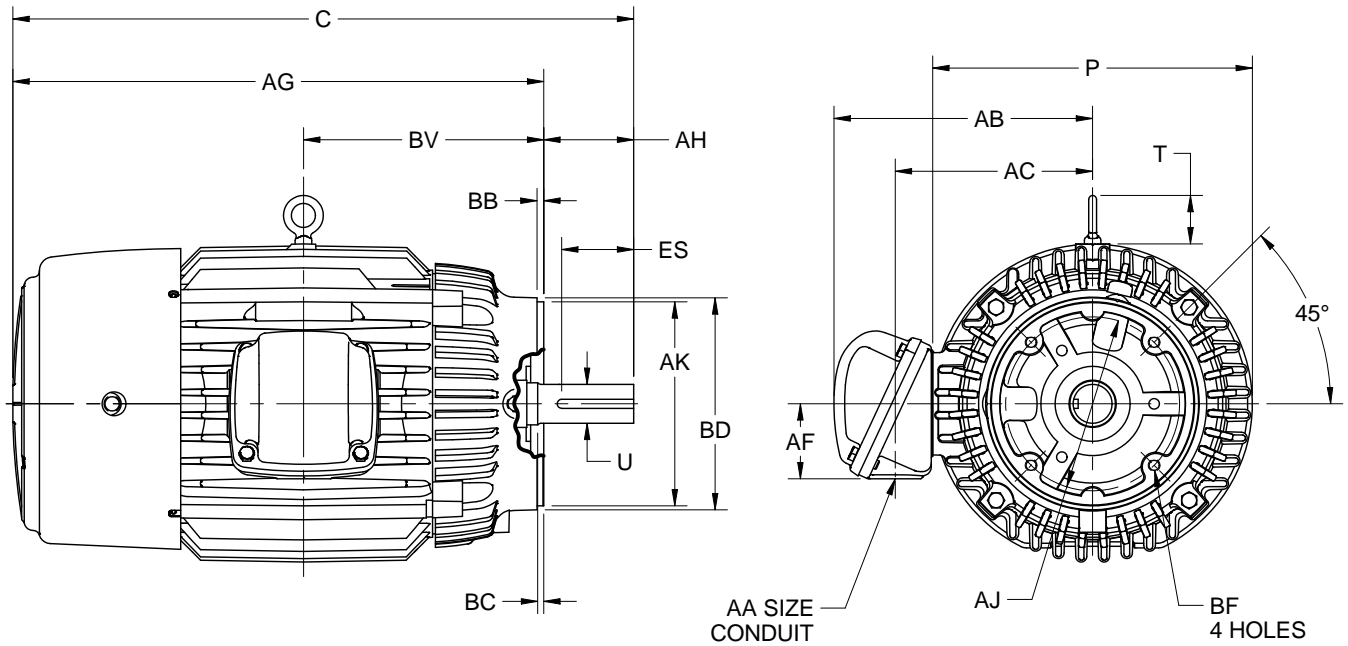

ALL DIMENSIONS ARE IN INCHES AND MILLIMETERS

UNITS	C	P <sup>2</sup>	T	U -.001	AA	AB	AC	AF	AG	AH
IN	25.59	13.31	2.03	1.625	1 1/2 NPT	10.78	8.22	3.13	21.72	3.75
MM	650	338	52	41.27		274	209	79	552	95

UNITS	AJ	AK -.005	BB MIN	BC	BD MAX	BF <sup>6</sup>	BV	ES MIN	SQ KEY
IN	7.250	8.500	.25	.25	9.00	1/2-13 X .75	10.00	2.88	.375
MM	184.15	215.90	6	6	229		254	73	9.52

TOLERANCES	
FACE RUNOUT	.004 T.I.R.
PERMISSIBLE ECCENTRICITY OF MOUNTING RABBET	.004 T.I.R.
PERMISSIBLE SHAFT RUNOUT	.002 T.I.R.

1. DIMENSIONS MAY VARY BY .25" DUE TO CASTING AND/OR FABRICATION VARIATIONS.
2. LARGEST MOTOR WIDTH.
3. CONDUIT BOX MAY BE LOCATED ON EITHER SIDE AND CONDUIT OPENING MAY BE LOCATED IN STEPS OF 90 DEGREES REGARDLESS OF LOCATION. STANDARD AS SHOW WITH CONDUIT OPENING DOWN.
4. TOLERANCES SHOWN ARE IN INCHES ONLY.
5. ALL TAPPED HOLES ARE UNIFIED NATIONAL COARSE, RIGHT HAND THREAD.
6. TAP SIZE AND BOLT PENETRATION ALLOWANCE.

07-2864/B

**Nidec Motor Corporation**  
St. Louis, Missouri

INFORMATION DISCLOSED ON THIS DOCUMENT IS CONSIDERED PROPRIETARY AND SHALL NOT BE REPRODUCED OR DISCLOSED WITHOUT WRITTEN CONSENT OF NIDEC MOTOR CORPORATION



ISSUED BY  
**R. KING**  
APPROVED BY  
**J. O'BRIEN**

IHP\_DP\_NMCA (MAR-2011) SOLIDEDGE