

EFFECTIVE:
21-MAR-14

SUPERSEDES:
03-APR-13

DIMENSION PRINT
TEFC, VERTICALLY MOUNTED WITH OVERSIZED BOX
FRAME: 250TC
BASIC TYPE: TCF, CEF

PRINT:
07-3056-01

SHEET:
1 OF 1

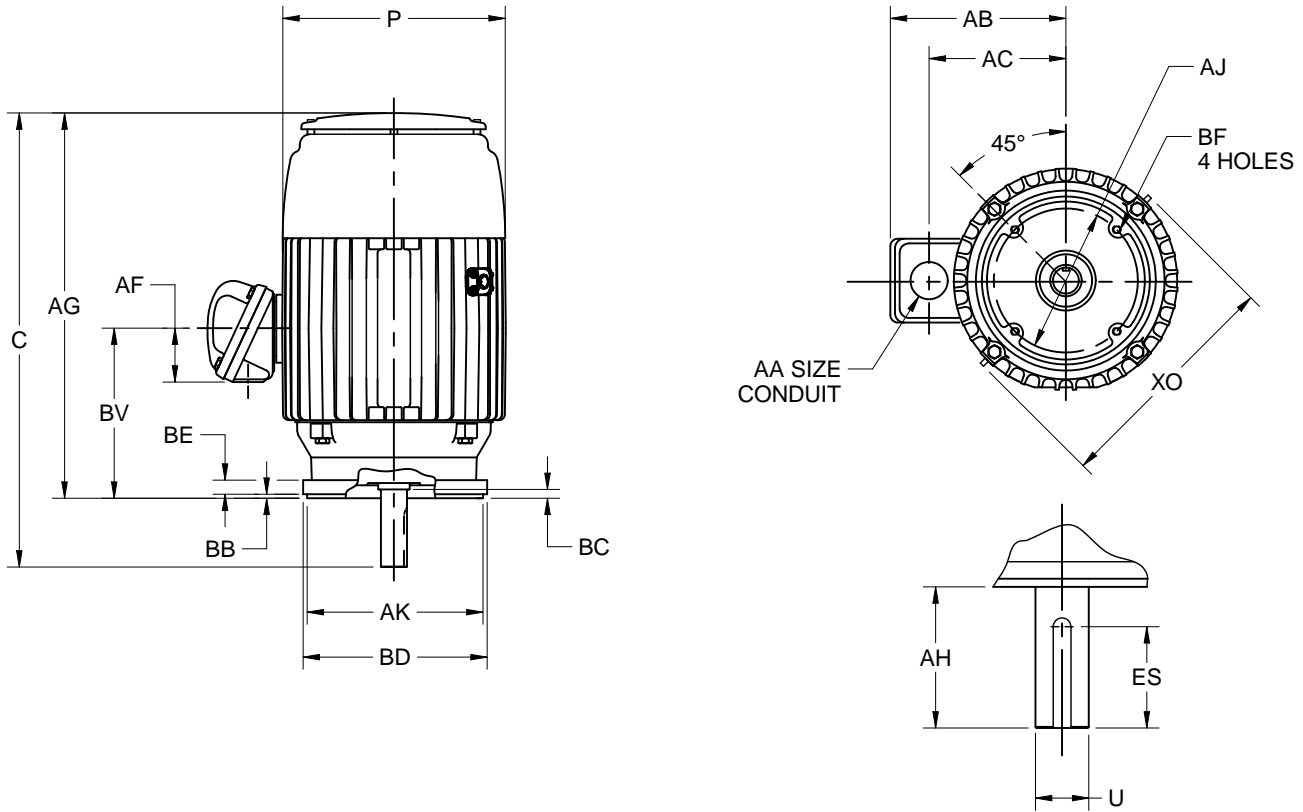

ALL DIMENSIONS ARE IN INCHES AND MILLIMETERS

UNITS	C	P ²	U -.001	AA	AB	AC	AF	AG	AH	AJ	AK -.003	BB MIN
IN	26.34	13.31	1.625	2 NPT	12.56	9.06	3.25	22.59	3.75	7.250	8.500	.31
MM	669	338	41.28		396	230	83	574	95	184.15	215.90	8

UNITS	BC	BD MAX	BE	BF ³	BV	ES MIN	SQ KEY	XO
IN	.25	10.00	.63	1/2-13X.75	10.00	2.91	.375	15.96
MM	6	254	3		254	74	9.53	405

1. ALL ROUGH DIMENSIONS MAY VARY BY .25" DUE TO CASTING AND/OR FABRICATION VARIATIONS.
2. LARGEST MOTOR WIDTH.
3. TAP SIZE AND BOLT PENETRATION ALLOWANCE.
4. CONDUIT BOX MAY BE LOCATED ON EITHER SIDE OR ON TOP OF MOTOR. CONDUIT OPENINGS MAY BE LOCATED IN STEPS OF 90 DEGREES REGARDLESS OF LOCATION. STANDARD AS SHOWN WITH CONDUIT OPENING DOWN.
5. ALL TAPPED HOLES ARE UNIFIED NATIONAL COARSE, RIGHT HAND THREAD.

TOLERANCES	
FACE RUNOUT	.004 T.I.R.
PERMISSIBLE ECCENTRICITY OF MOUNTING RABBET	.004 T.I.R.
PERMISSIBLE SHAFT RUNOUT	.002 T.I.R.
FOR SPECIAL SHAFT RUNOUT	.001 T.I.R.

07-3056/A

Nidec Motor Corporation
St. Louis, Missouri

INFORMATION DISCLOSED ON THIS DOCUMENT IS CONSIDERED PROPRIETARY AND SHALL NOT BE REPRODUCED OR DISCLOSED WITHOUT WRITTEN CONSENT OF NIDEC MOTOR CORPORATION



ISSUED BY
R. KING
APPROVED BY
J. WAIDMANN

IHP_DP_NMCA (MAR-2011) SOLIDEDGE