

EFFECTIVE:
25-APR-13

DIMENSION PRINT
WITH OVERSIZED OUTLET BOX

PRINT:
07-3067

SUPERSEDES:
NEW

FRAME: 320TS
BASIC TYPE: LC, NC

SHEET:
1 OF 1

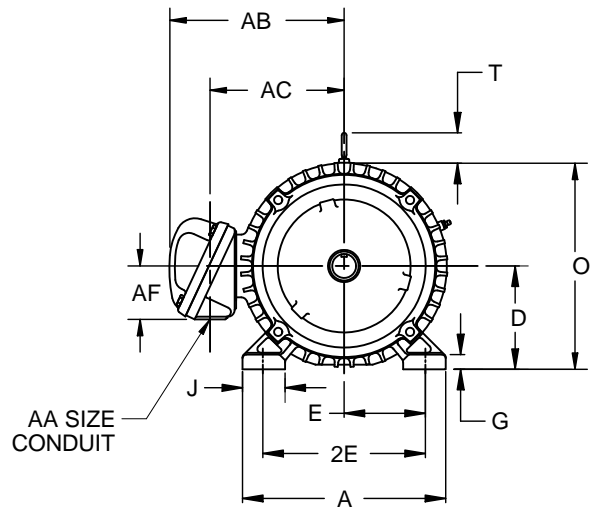
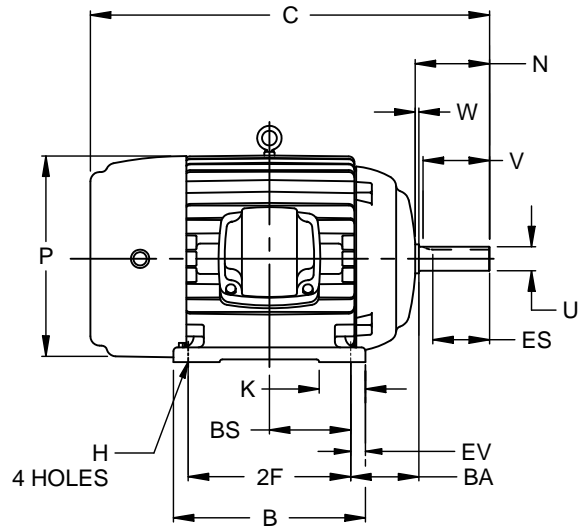

ALL DIMENSIONS ARE IN INCHES AND MILLIMETERS

UNITS	A	B	C	D -.06	E	2E ±.03	G	H +.05	J	K	N	O
IN	15.75	15.00	29.19	8.00	6.25	12.50	1.13	.66	3.25	4.65	4.13	16.38
MM	400	381	741	203	159	318	29	17	83	118	105	416

UNITS	P ²	T	U -.001	V MIN	W	AA	AB	AC	AF	BA	BS	ES MIN
IN	16.75	2.03	1.875	3.50	.38	3 NPT	18.03	13.00	4.56	5.25	6.00	2.03
MM	425	52	47.63	89	10		458	330	116	133	152	52

UNITS	EV	SQ KEY
IN	1.50	.500
MM	38	12.70

FRAME	UNITS	2F ±.03
324TS	IN	10.50
	MM	267
3326TS	IN	12.00
	MM	305

1. ALL ROUGH CASTING DIMENSIONS MAY VARY BY .25" DUE TO CASTING AND/OR FABRICATION VARIATIONS.
2. LARGEST MOTOR WIDTH.
3. TOLERANCES SHOWN ARE IN INCHES ONLY.

4. STANDARD ASSEMBLY POSITION F-1 IS SHOWN F-2 IS PROVIDED WHEN SPECIFIED. CONDUIT OPENINGS MAY BE LOCATED IN STEPS OF 90 DEGREES REGARDLESS OF LOCATION. STANDARD AS SHOWN WITH CONDUIT OPENING DOWN.

07-3067/-

Nidec Motor Corporation
St. Louis, Missouri

INFORMATION DISCLOSED ON THIS DOCUMENT IS CONSIDERED PROPRIETARY AND SHALL NOT BE REPRODUCED OR DISCLOSED WITHOUT WRITTEN CONSENT OF NIDEC MOTOR CORPORATION



ISSUED BY
S. MONTALVO
APPROVED BY
J. SALINAS

IHP_DP_NMCA (MAR-2011) SOLIDEDGE