

EFFECTIVE:
29-JUN-16

DIMENSION PRINT

PRINT:
07-3245

SUPERSEDES:
NEW

FRAME: 56
BASIC TYPE: UT

SHEET:
1 OF 1

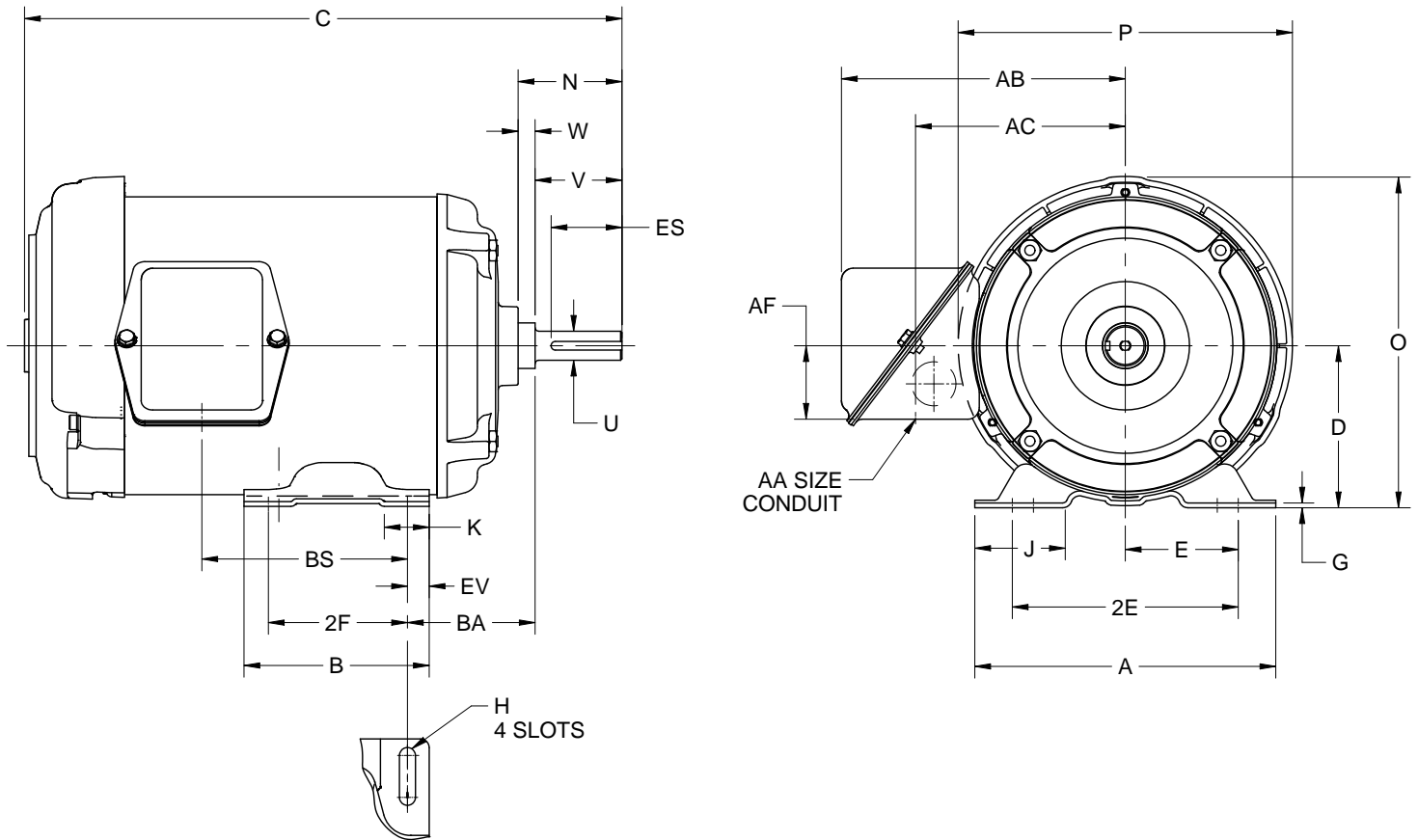

ALL DIMENSIONS ARE IN INCHES AND MILLIMETERS

UNITS	A	B	C	D	E	2E	2F	G	H	J	K	N	O
IN	6.50	4.00	12.91	3.50	2.44	4.88	3.00	.13	.34 X 1.25	1.97	.97	2.24	7.14
MM	165	102	328	89	62	124	76	3	9 X 32	50	25	57	181

UNITS	P ²	U	V	W	AA ³	AB	AC	AF	BA	BS	ES	EV	SQ
IN	7.31	.6250	1.87	.38	.75	6.13	4.53	1.59	2.75	4.44	1.41	.47	.188
MM	186	15.875	48	10		156	115	40	69	113	36	12	4.78

1. DIMENSIONS MAY VARY .25" DUE TO CASTING AND/OR FABRICATION VARIATIONS
2. LARGEST MOTOR WIDTH
3. BASIC CONDUIT FITTING SIZE. HOLE OPENING ON THE SIDE OF THE CONDUIT BOX (REPRESENTED BY A DASHED CIRCLE) WILL ACCEPT A .50 BASIC CONDUIT FITTING
4. THE CONDUIT BOX MAY BE LOCATED ON EITHER SIDE OF THE MOTOR. THE CONDUIT OPENING(S) MAY BE LOCATED IN STEPS OF 180° REGARDLESS OF LOCATION. STANDARD LOCATION IS SHOWN WITH THE CONDUIT OPENING DOWN
5. TOLERANCES ARE SHOWN IN INCHES ONLY
6. FRAME REFERENCE; 6.75/56

07-3245/-

Nidec Motor Corporation
St. Louis, Missouri

INFORMATION DISCLOSED ON THIS DOCUMENT IS CONSIDERED PROPRIETARY AND SHALL NOT BE REPRODUCED OR DISCLOSED WITHOUT WRITTEN CONSENT OF NIDEC MOTOR CORPORATION



ISSUED BY
F. CRUZ
APPROVED BY
G. CORONADO

IHP_DP_NMCA (MAR-2011) SOLIDEDGE