

EFFECTIVE:  
**20-OCT-16**

SUPERSEDES:  
**NEW**

**DIMENSION PRINT**  
TEFC W/ BRAKE  
FRAME: 280T  
BASIC TYPE: TC

PRINT:  
**07-3270**

SHEET:  
**1 OF 1**

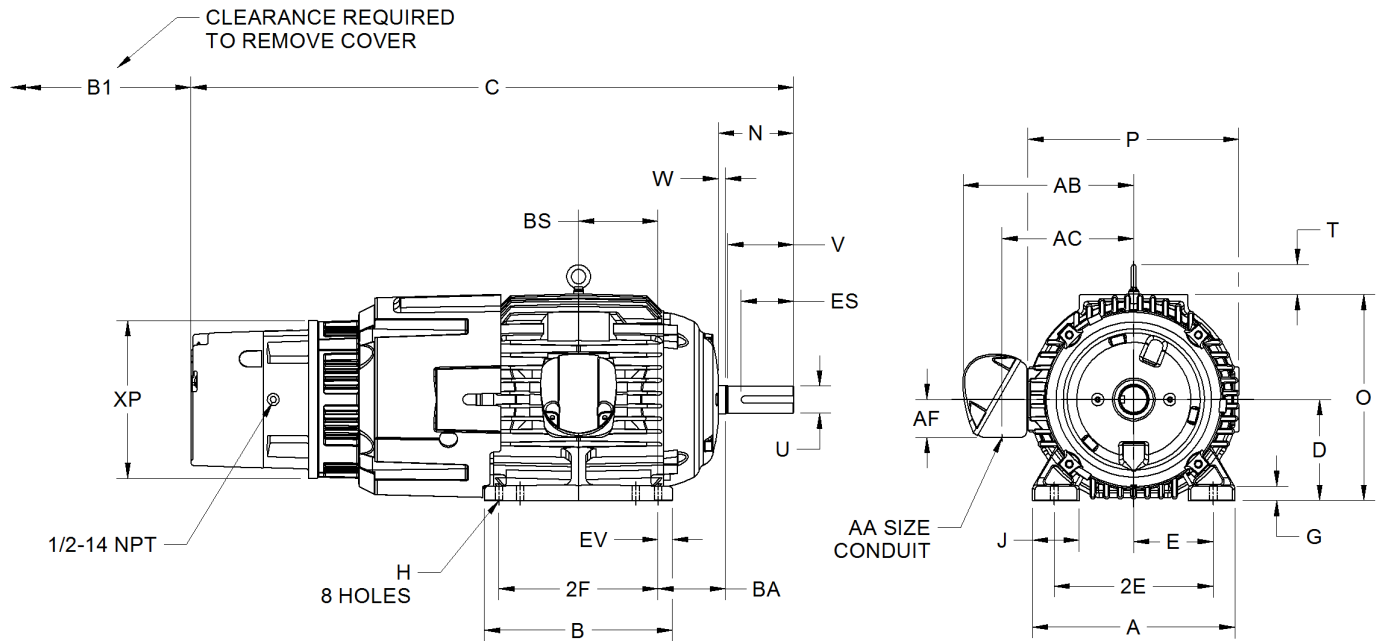

ALL DIMENSIONS ARE IN INCHES AND MILLIMETERS

UNITS	A	B	C	D -.06	E	2E ±.03	G	H +.05	J	N	O
IN	14.00	13.00	41.75	7.00	5.50	11.00	1.00	.53	3.25	5.16	14.31
MM	356	330	1060	178	140	279	25	14	63	131	363

UNITS	P <sup>2</sup>	T	U -.001	V MIN	W	AA	AB	AC	AF	B1	BA
IN	14.63	2.06	1.875	4.38	.56	1.5 NPT	11.88	9.13	2.63	4.69	4.75
MM	372	52	47.63	111	14		302	232	67	119	67

UNITS	BS	ES MIN	EV	SQ KEY	XP
IN	5.50	3.28	1.00	.500	10.94
MM	140	83	25	12.70	278

FRAME	UNITS	2F ±.03
284T	IN	9.50
	MM	241
286T	IN	11.00
	MM	279

NOTE: THIS DIMENSION PRINT IS GOOD FOR STEARNS  
SERIES 1-087-1XX-00, IP54 ENCLOSURE,  
RANGING FROM 105 THRU 125 LB-FT.

1. DIMENSIONS MAY VARY .25" DUE TO CASTING AND/OR FABRICATION VARIATIONS.
2. LARGEST MOTOR WIDTH.
3. TOLERANCES ARE SHOWN IN INCHES.
4. CONDUIT BOX MAY BE LOCATED ON EITHER SIDE OF MOTOR. CONDUIT OPENINGS MAY BE LOCATED IN STEPS OF 90 DEGREES REGARDLESS OF LOCATION. STANDARD AS SHOWN WITH CONDUIT OPENING DOWN.

07-3270/-

**Nidec Motor Corporation**  
St. Louis, Missouri

INFORMATION DISCLOSED ON THIS DOCUMENT  
IS CONSIDERED PROPRIETARY AND SHALL NOT BE  
REPRODUCED OR DISCLOSED WITHOUT WRITTEN  
CONSENT OF NIDEC MOTOR CORPORATION



ISSUED BY  
**G. MARTINEZ**  
APPROVED BY  
**T. PALLETT**

IHP\_DP\_NMCA (MAR-2011) SOLIDEDGE