

EFFECTIVE:
03-AUG-16

SUPERSEDES:
NEW

DIMENSION PRINT
TEFC W/ BRAKE
FRAME: 320T, TS
BASIC TYPE: TC

PRINT:
07-3273

SHEET:
1 OF 1

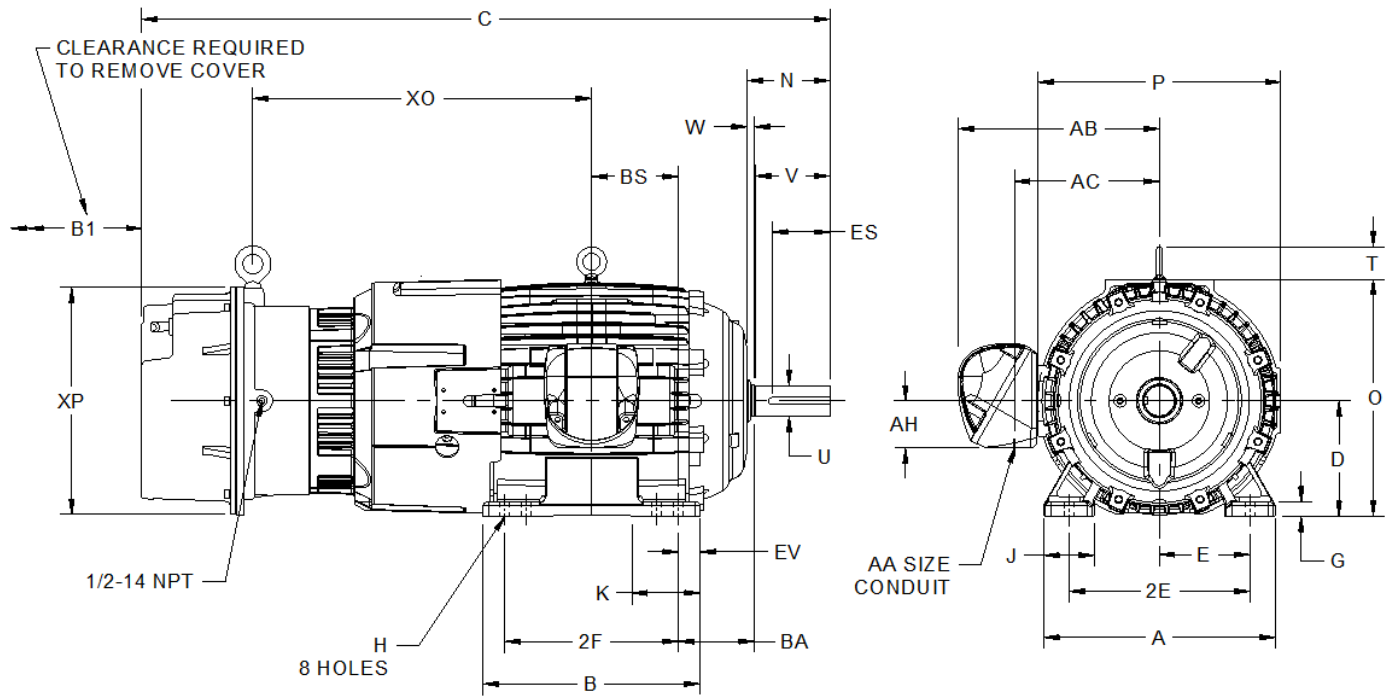

ALL DIMENSIONS ARE IN INCHES AND MILLIMETERS

UNITS	A	B	D -.06	E	2E ±.03	G	H +.05	J	K	O	P ²
IN	16.00	15.00	8.00	6.25	12.50	1.00	.66	3.50	4.75	16.38	16.38
MM	406	381	203	159	318	25	17	89	121	416	416

UNITS	T	W	AA	AB	AC	AF	B1	BA	BS	EV	SQ KEY
IN	2.31	.47	2 NPT	13.94	10.19	3.25	6.00	5.25	6.00	1.50	.500
MM	59	12		354	259	83	152	133	152	38	12.70

UNITS	XO	XP
IN	23.44	15.75
MM	595	400

FRAME	UNITS	C	N	U -.001	V MIN	ES MIN
324, 326T	IN	47.63	5.75	2.125	5.00	3.91
	MM	1210	146	53.98	127	99
324, 326TS	IN	46.13	4.25	1.875	3.50	2.03
	MM	1172	108	47.63	89	52

FRAME	UNITS	2F ±.03
324T, TS	IN	10.50
	MM	267
326T, TS	IN	12.00
	MM	305

1. DIMENSIONS MAY VARY .25" DUE TO CASTING AND/OR FABRICATION VARIATIONS
2. LARGEST MOTOR WIDTH
3. STANDARD ASSEMBLY POSITION F-1 IS SHOWN. F-2 IS PROVIDED WHEN SPECIFIED. CONDUIT OPENINGS MAY BE LOCATED IN STEPS OF 90° REGARDLESS OF THE LOCATION
4. TOLERANCES ARE SHOWN IN INCHES ONLY

NOTE: THIS DIMENSION PRINT IS GOOD FOR STEARNS SERIES 1-081-032-02 IP54 ENCLOSURE, 230 LB-FT

07-3194/-

Nidec Motor Corporation
St. Louis, Missouri

INFORMATION DISCLOSED ON THIS DOCUMENT IS CONSIDERED PROPRIETARY AND SHALL NOT BE REPRODUCED OR DISCLOSED WITHOUT WRITTEN CONSENT OF NIDEC MOTOR CORPORATION



ISSUED BY
F. CRUZ
APPROVED BY
T. PALLETT

IHP_DP_NMCA (MAR-2011) SOLIDEDGE