

EFFECTIVE:  
**10-AUG-16**

SUPERSEDES:  
**NEW**

**DIMENSION PRINT**  
TEBC (RADIAL) W/ BRAKE  
FRAME: 360T, TS  
BASIC TYPE: TCB, TCBI

PRINT:  
**07-3275**

SHEET:  
**1 OF 1**

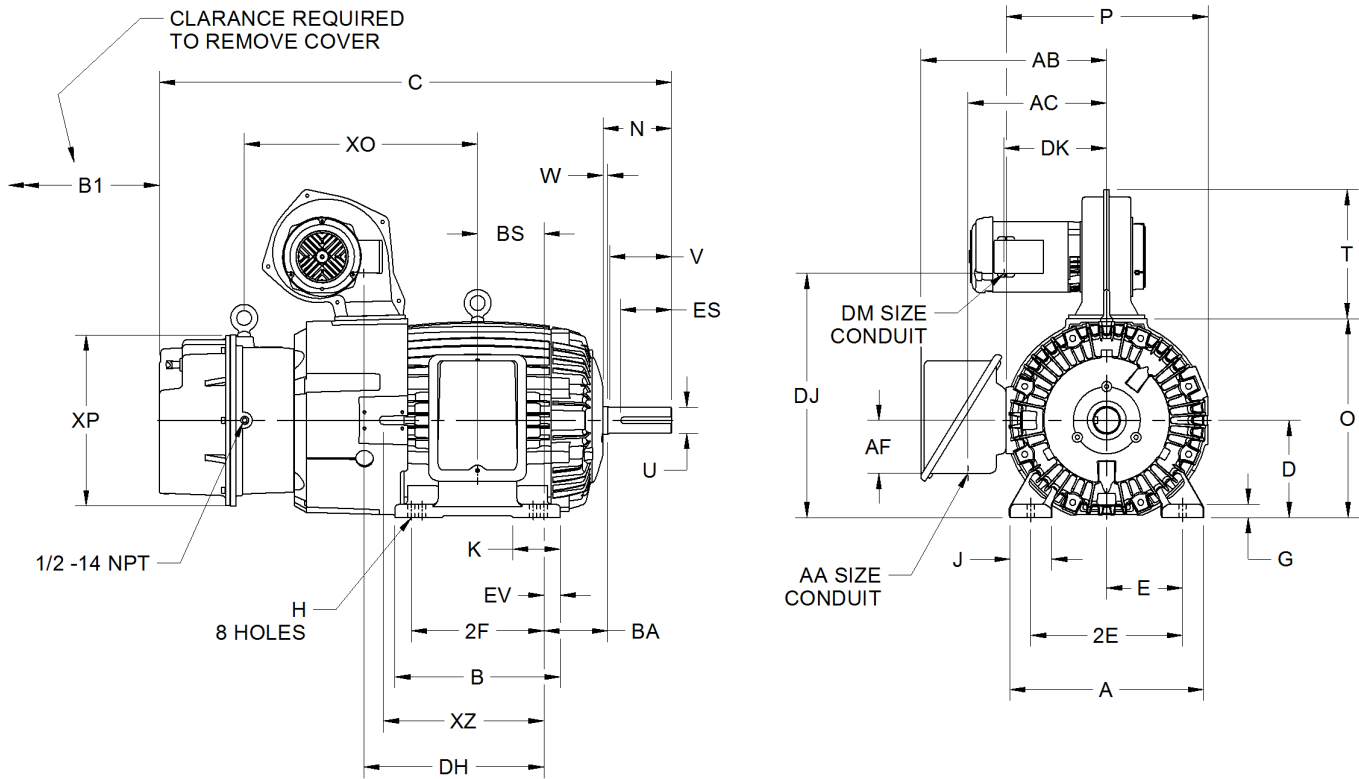

ALL DIMENSIONS ARE IN INCHES AND MILLIMETERS

UNITS	A	B	D -.06	E	2E ±.03	G	H +.05	J	K	O	P <sup>2</sup>
IN	17.94	15.25	9.00	7.00	14.00	1.22	.66	3.94	4.38	18.31	18.13
MM	456	387	229	178	356	31	17	100	111	465	460

UNITS	T	W	AA	AB	AC	AF	B1	BA	BS	DH	DJ
IN	11.94	.44	3 NPT	17.19	12.81	4.88	6.00	5.88	6.13	15.88	22.50
MM	303	11		437	325	124	152	149	156	403	572

UNITS	DK	DM	EV	XO	XP	XZ
IN	10.38	.75	1.50	21.56	15.75	14.81
MM	264		38	548	400	376

FRAME	UNITS	C	N	U -.001	V MIN	ES MIN	SQ KEY
364, 365T	IN	47.25	6.31	2.375	5.62	4.28	.625
	MM	1200	160	60.33	143	109	15.88
364, 365TS	IN	45.13	4.19	1.875	3.50	2.03	.500
	MM	1146	106	47.63	89	52	12.70

FRAME	UNITS	2F ±.03
364T, TS	IN	11.25
	MM	286
365T, TS	IN	12.25
	MM	311

1. DIMENSIONS MAY VARY .25" DUE TO CASTING AND/OR FABRICATION VARIATIONS
2. LARGEST MOTOR WIDTH
3. STANDARD ASSEMBLY POSITION F-1 IS SHOWN. F-2 IS PROVIDED WHEN SPECIFIED. CONDUIT OPENINGS MAY BE LOCATED IN STEPS OF 90° REGARDLESS OF THE LOCATION
4. TOLERANCES ARE SHOWN IN INCHES ONLY

NOTE: THIS DIMENSION PRINT IS GOOD FOR STEARNS SERIES 1-082-XXX-02, IP 54 ENCLOSURE, RANGING FROM 125 THRU 330 LB-FT.

07-3269/-

**Nidec Motor Corporation**  
St. Louis, Missouri

INFORMATION DISCLOSED ON THIS DOCUMENT IS CONSIDERED PROPRIETARY AND SHALL NOT BE REPRODUCED OR DISCLOSED WITHOUT WRITTEN CONSENT OF NIDEC MOTOR CORPORATION



ISSUED BY  
**R. MARTINEZ**  
APPROVED BY  
**T. PALLETT**

IHP\_DP\_NMCA (MAR-2011) SOLIDEDGE