

EFFECTIVE:
16-NOV-16

SUPERSEDES:
NEW

DIMENSION PRINT
CLOSE-COUPLED PUMP (VERTICALLY MOUNTED) WITH OVERSIZE CONDUIT BOX
FRAME: 250JM
BASIC TYPE: DEF4

PRINT:
07-3302

SHEET:
1 OF 1

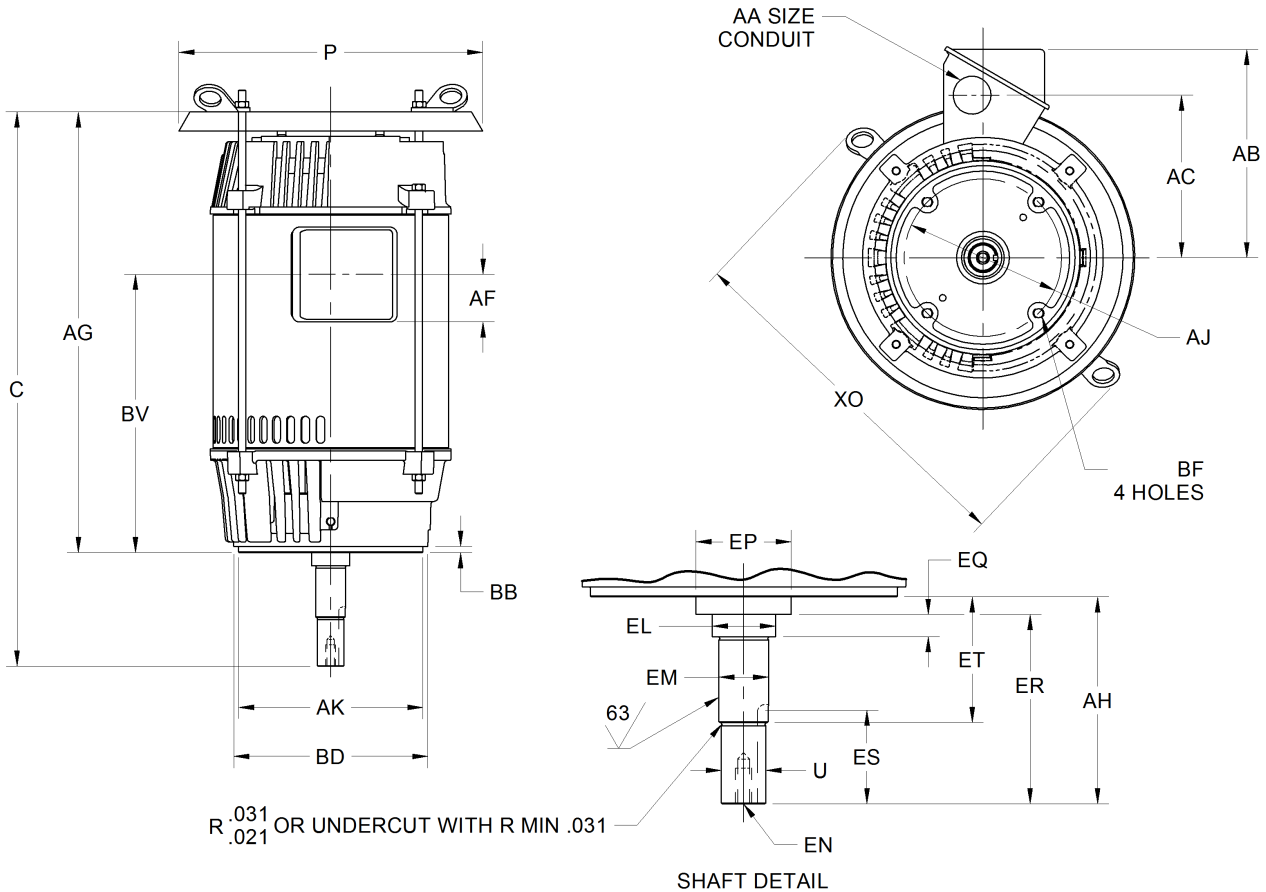

ALL DIMENSIONS ARE IN INCHES AND MILLIMETERS

UNITS	P ²	AA	AB	AC	AF	AJ	AK ⁵	BB ⁵	BD	U ⁵	AH ⁵	BF ³
IN	14.00	1.50 NPT	10.57	8.32	2.59	7.250	8.500	.313	10.00	1.2495	5.250	1/2-13 X .75
MM	356		268	211	66	184.15	215.90	7.95	254	31.737	133.35	

UNITS	EL ⁵	EM ⁵	EN ³	EP	EQ ⁵	ER	ES	ET ⁵	XO	SQ	KEY
IN	1.750	1.3750	1/2-13 X 1.00	1.75	2.375	5.25	2.53	3.000	16.81	.250	
MM	44.45	34.925		44	60.33	133	64	76.20	427	6.35	

FRAME	UNITS	C	AG	BV
254JM	IN	25.50	20.25	13.75
	MM	648	514	349
256JM	IN	26.13	20.88	14.38
	MM	664	530	365

1. ALL ROUGH CASTING DIMENSIONS MAY VARY BY .25 IN DUE TO CASTING AND/OR FABRICATION VARIATIONS.
2. LARGEST MOTOR WIDTH.
3. TAP SIZE AND BOLT PENETRATION ALLOWANCE.
4. CONDUIT BOX MAY BE LOCATED ON EITHER SIDE AND CONDUIT OPENING MAY BE LOCATED IN STEPS OF 90 DEGREES REGARDLESS OF LOCATION. STANDARD AS SHOWN WITH CONDUIT OPENING DOWN.
5. TOLERANCES SHOWN ARE IN INCHES ONLY.
6. FRAME REFERENCE: 11.125"/254//11.750"/256

TOLERANCES	
FACE RUNOUT	.004 T.I.R.
PERMISSIBLE ECCENTRICITY OF MOUNTING RABBET	.004 T.I.R.
PERMISSIBLE SHAFT RUNOUT	.002 T.I.R.

ISSUED BY
R. MARTINEZ
APPROVED BY
M. OLVERA

Nidec Motor Corporation
St. Louis, Missouri

INFORMATION DISCLOSED ON THIS DOCUMENT IS CONSIDERED PROPRIETARY AND SHALL NOT BE REPRODUCED OR DISCLOSED WITHOUT WRITTEN CONSENT OF NIDEC MOTOR CORPORATION



IHP_DP_NMCA (MAR-2011) SOLIDEDGE