

EFFECTIVE:
04-MAR-20

DIMENSION PRINT

STEEL EDGE CLOSE COUPLE PUMP WITH OVERSIZE OUTLET BOX CANOPY CAP

PRINT:
07-3431-01

SUPERSEDES:
NEW

FRAME: 254, 256JM, JP
BASIC TYPE: SEF4, SEF1

SHEET:
1 OF 1

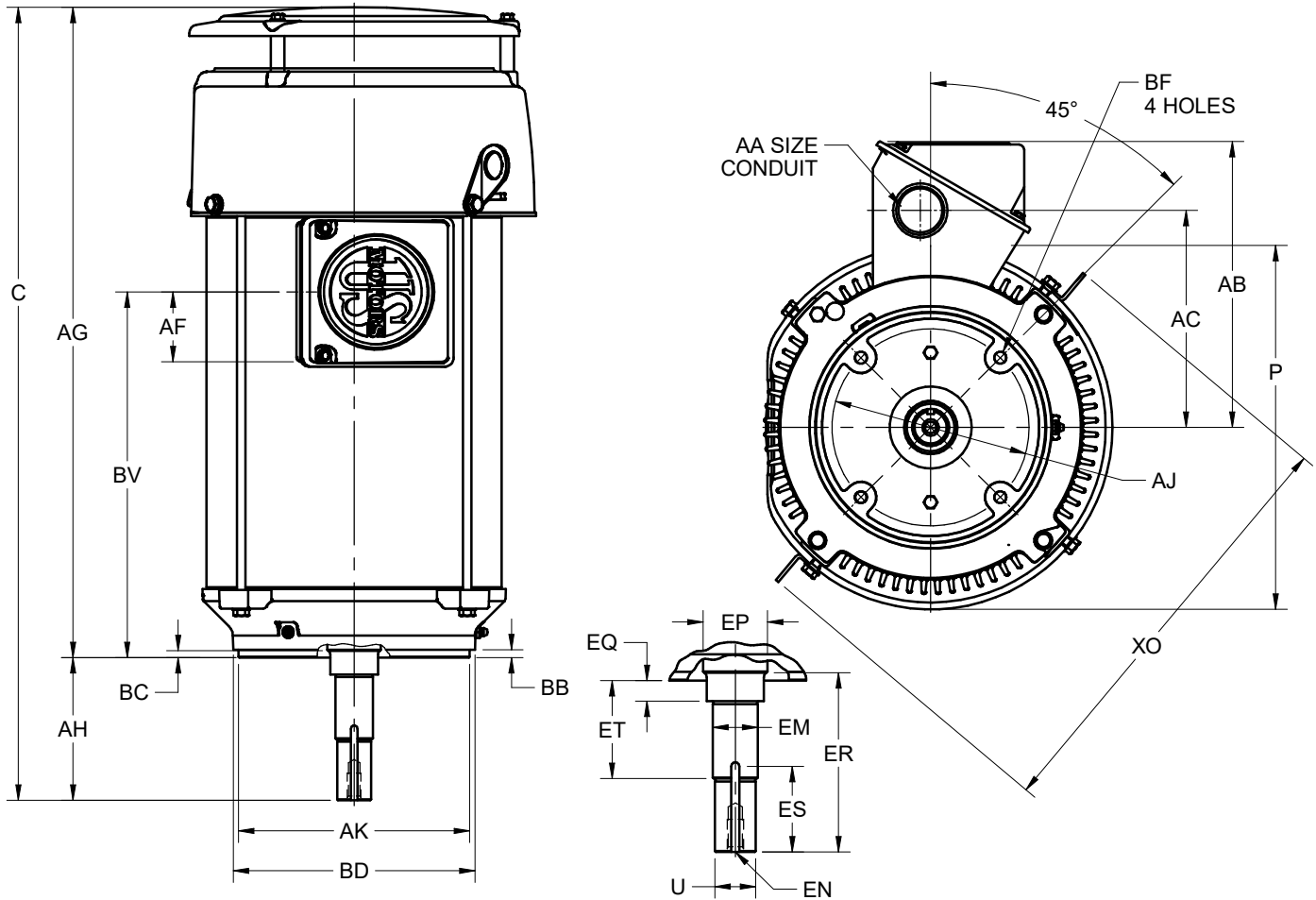

ALL DIMENSIONS ARE IN INCHES AND MILLIMETERS

UNITS	P ²	U -.0005	AA ⁵	AB	AC	AF	AG	AJ	AK -.003	BB MIN	BC	BD
IN	13.38	1.2495	1.50	10.53	8.00	2.59	23.94	7.250	8.500	.25	.25	9.00
MM	340	31.737		267	203	66	608	184.15	215.90	6	6	229

UNITS	BF ^{3,4}	BV	EL -.002	EM -.0005	EN ^{3,4}	EP MIN	XO	ES MIN	SQ KEY
IN	1/2-13 X .75	13.44	1.750	1.3750	1/2-13 X 1.00	1.75	15.94	2.53	.250
MM		341	44.45	34.925		44	405	64	6.35

FRAME	UNITS	C	AH ±.031	EQ ±.015	ER MIN	ET ±.015
250JM	IN	29.19	5.250	.625	5.25	3.000
	MM	741	113.35	15.88	113	76.20
250JP	IN	32.06	8.125	2.375	8.13	5.875
	MM	814	206.38	60.33	207	149.23

TOLERANCES	
FACE RUNOUT	.004 TIR
PERMISSIBLE ECCENTRICITY OF MOUNTING RABBET	.004 TIR
PERMISSIBLE SHAFT RUNOUT	.002 TIR

1. DIMENSIONS MAY VARY .25" DUE TO CASTING AND/OR FABRICATION VARIATIONS
2. LARGEST MOTOR WIDTH
3. ALL TAP HOLES ARE UNIFIED NATIONAL COARSE, RIGHT HAND THREAD
4. TAP SIZE AND BOLT PENETRATION ALLOWANCE
5. BASIC CONDUIT FITTING SIZE. CONDUIT OPENING ON THE SIDE OF THE CONDUIT BOX WILL ACCEPT 1-1/2 NPT CONDUIT FITTING
6. CONDUIT OPENING(S) MAY BE LOCATED IN STEPS OF 180° REGARDLESS OF LOCATION. STANDARD LOCATION IS SHOWN WITH CONDUIT OPENING DOWN
7. TOLERANCES ARE SHOWN IN INCHES ONLY
8. FRAME REFERENCE: 14.000/254/256

07-3431-01/-

Nidec Motor Corporation
St. Louis, Missouri

INFORMATION DISCLOSED ON THIS DOCUMENT
IS CONSIDERED PROPRIETARY AND SHALL NOT BE
REPRODUCED OR DISCLOSED WITHOUT WRITTEN
CONSENT OF NIDEC MOTOR CORPORATION



ISSUED BY
R. TIMMERMANN
APPROVED BY
P. HOGG

IHP_DP_NMCA (MAR-2011) SOLIDEDGE