

EFFECTIVE:
02-FEB-18

SUPERSEDES:
15-DEC-16

DIMENSION PRINT
WORLD MOTOR CORRODUTY
FRAME: 284TS, 286TS
BASIC TYPE: TC

PRINT:
08-1000

SHEET:
1 OF 1

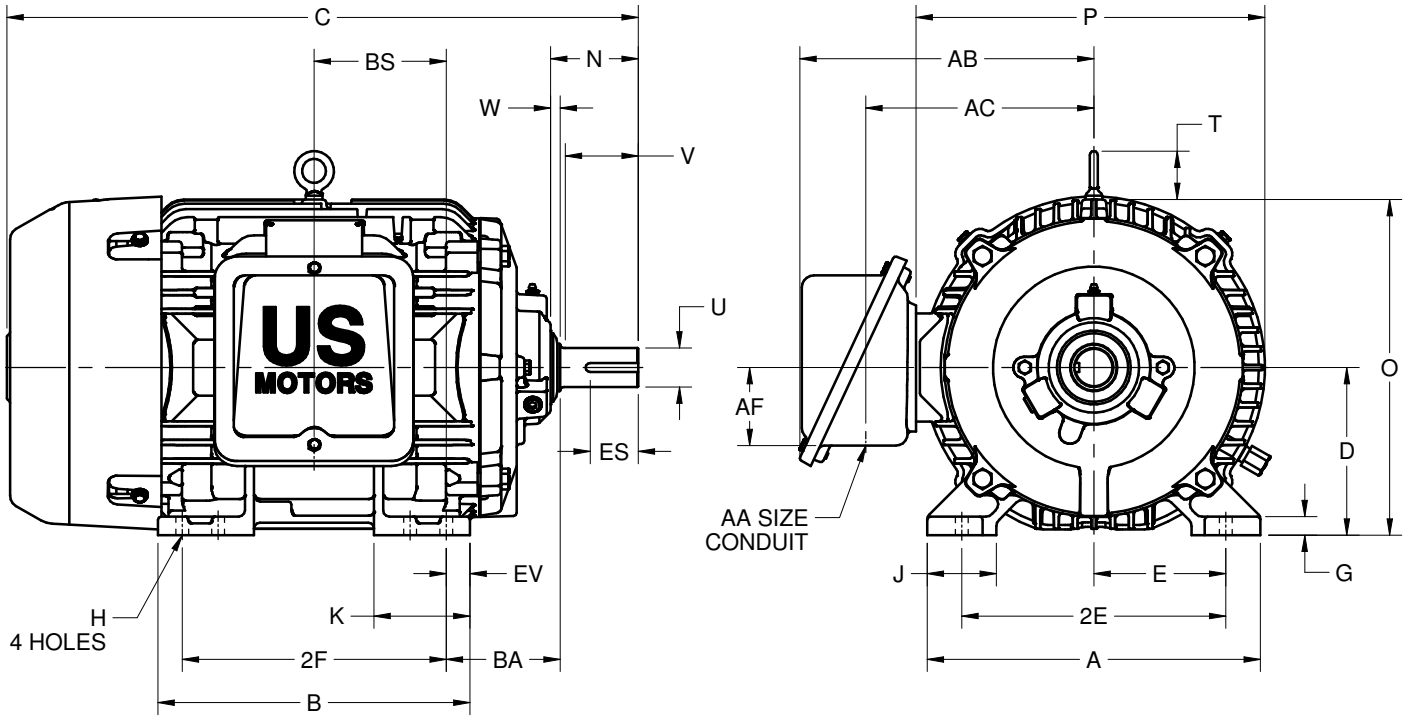

ALL DIMENSIONS ARE IN INCHES AND MILLIMETERS

UNITS	A	B	C	D -.06	E	2E ±.03	G	H +.05	J	K	N	O	P ²
IN	13.88	13.00	26.31	7.00	5.50	11.00	.78	.53	2.88	4.00	3.66	14.00	14.78
MM	353	330	668	178	140	279	20	13	73	102	93	356	375

UNITS	T	U -.001	V MIN	W	AA	AB	AC	AF	BA	BS	EV	ES MIN	SQ KEY
IN	2.03	1.625	3.00	.41	1-1/2 NPT	12.25	9.50	3.25	4.75	5.50	1.00	1.91	.375
MM	52	41.28	76	10		311	241	83	121	140	25	49	9.53

FRAME	UNITS	2F ±.03
284TS	IN	9.50
	MM	241
286TS	IN	11.00
	MM	279

1. DIMENSIONS MAY VARY .25" DUE TO CASTING AND/OR FABRICATION VARIATIONS
2. LARGEST MOTOR WIDTH
3. STANDARD ASSEMBLY POSITION F-1 IS SHOWN. F-2 IS PROVIDED WHEN SPECIFIED. CONDUIT OPENING MAY BE LOCATED IN STEPS OF 90° REGARDLESS OF THE LOCATION
4. TOLERANCES ARE SHOWN IN INCHES ONLY

08-1000/A

Nidec Motor Corporation
St. Louis, Missouri

INFORMATION DISCLOSED ON THIS DOCUMENT IS CONSIDERED PROPRIETARY AND SHALL NOT BE REPRODUCED OR DISCLOSED WITHOUT WRITTEN CONSENT OF NIDEC MOTOR CORPORATION



ISSUED BY
R. TIMMERMANN
APPROVED BY
M. CULLEN

IHP_DP_NMCA (MAR-2011) SOLIDEDGE