

EFFECTIVE:  
**17-JUL-17**

SUPERSEDES:  
**NEW**

**DIMENSION PRINT**  
WORLD MOTOR CORRODUTY  
FRAME: 404TS, 405TS  
BASIC TYPE: TC

PRINT:  
**08-1058**

SHEET:  
**1 OF 1**

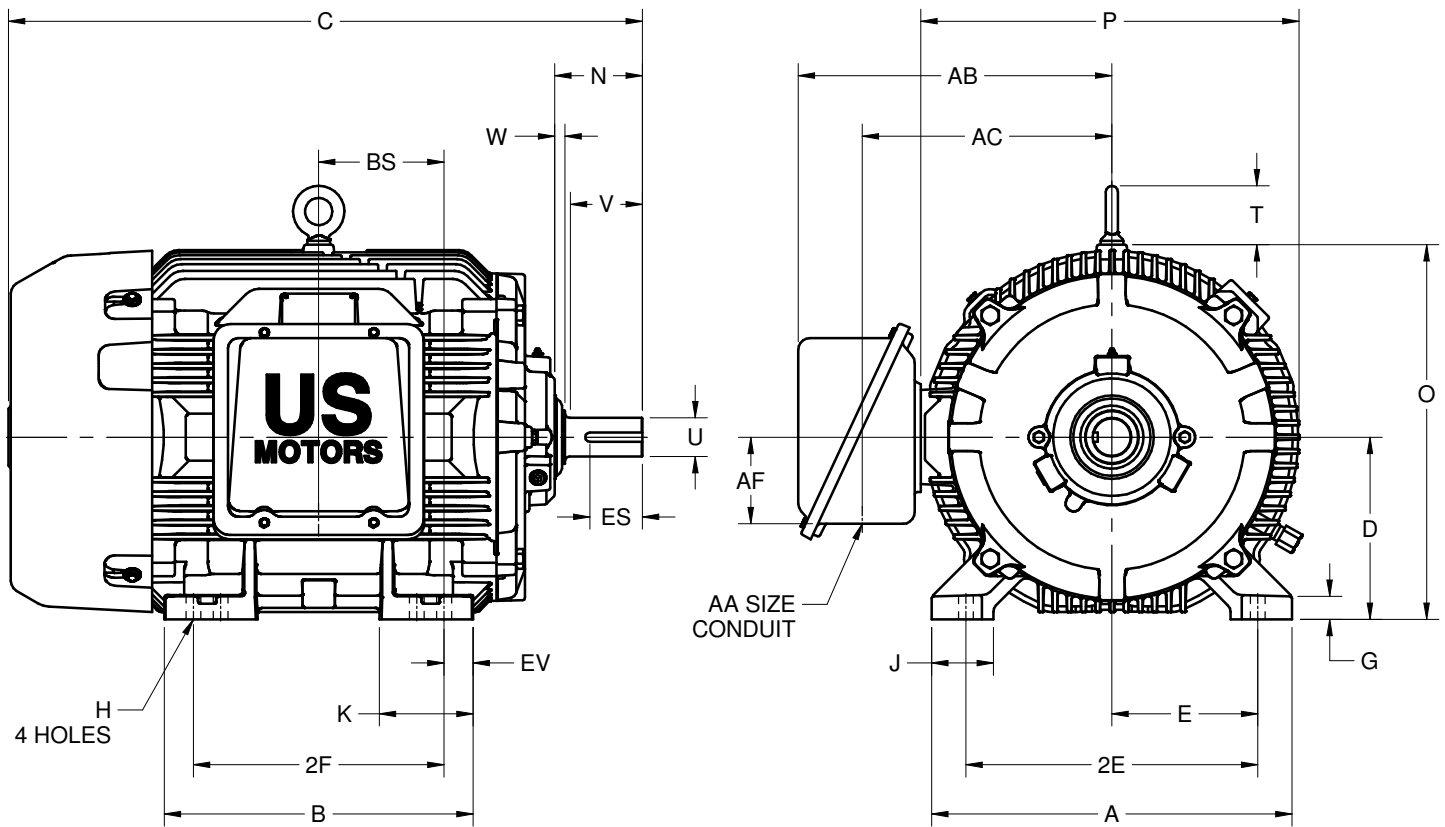

ALL DIMENSIONS ARE IN INCHES AND MILLIMETERS

UNITS	A	B	C	D -.06	E	2E ±.03	G	H +.05	J	K	N	O	P <sup>2</sup>
IN	19.75	16.94	34.75	10.00	8.00	16.00	1.25	.81	3.38	5.13	4.81	20.56	20.94
MM	502	430	883	254	203	406	32	21	86	130	122	522	532

UNITS	T	U -.001	V MIN	W	AA	AB	AC	AF	BA	BS	EV	ES MIN	SQ KEY
IN	3.22	2.125	4.00	.56	3 NPT	17.19	13.69	4.75	6.62	6.88	1.59	2.78	.500
MM	82	53.98	102	14		437	348	121	168	175	40	71	12.70

FRAME	UNITS	2F ±.03
404TS	IN	12.25
	MM	311
405TS	IN	13.75
	MM	349

1. DIMENSIONS MAY VARY .25" DUE TO CASTING AND/OR FABRICATION VARIATIONS
2. LARGEST MOTOR WIDTH
3. STANDARD ASSEMBLY POSITION F-1 IS SHOWN. F-2 IS PROVIDED WHEN SPECIFIED. CONDUIT OPENING MAY BE LOCATED IN STEPS OF 90° REGARDLESS OF THE LOCATION
4. TOLERANCES ARE SHOWN IN INCHES ONLY

08-1058/-

**Nidec Motor Corporation**  
St. Louis, Missouri

INFORMATION DISCLOSED ON THIS DOCUMENT IS CONSIDERED PROPRIETARY AND SHALL NOT BE REPRODUCED OR DISCLOSED WITHOUT WRITTEN CONSENT OF NIDEC MOTOR CORPORATION



ISSUED BY  
**R. TIMMERMANN**  
APPROVED BY  
**M. CULLEN**

IHP\_DP\_NMCA (MAR-2011) SOLIDEDGE