

EFFECTIVE:
24-AUG-17

SUPERSEDES:
NEW

DIMENSION PRINT
WORLD MOTOR HOSTILE DUTY WITH OVERSIZED OUTLET BOX
FRAME: 404TS, 405TS
BASIC TYPE: CT

PRINT:
08-1062-02

SHEET:
1 OF 1

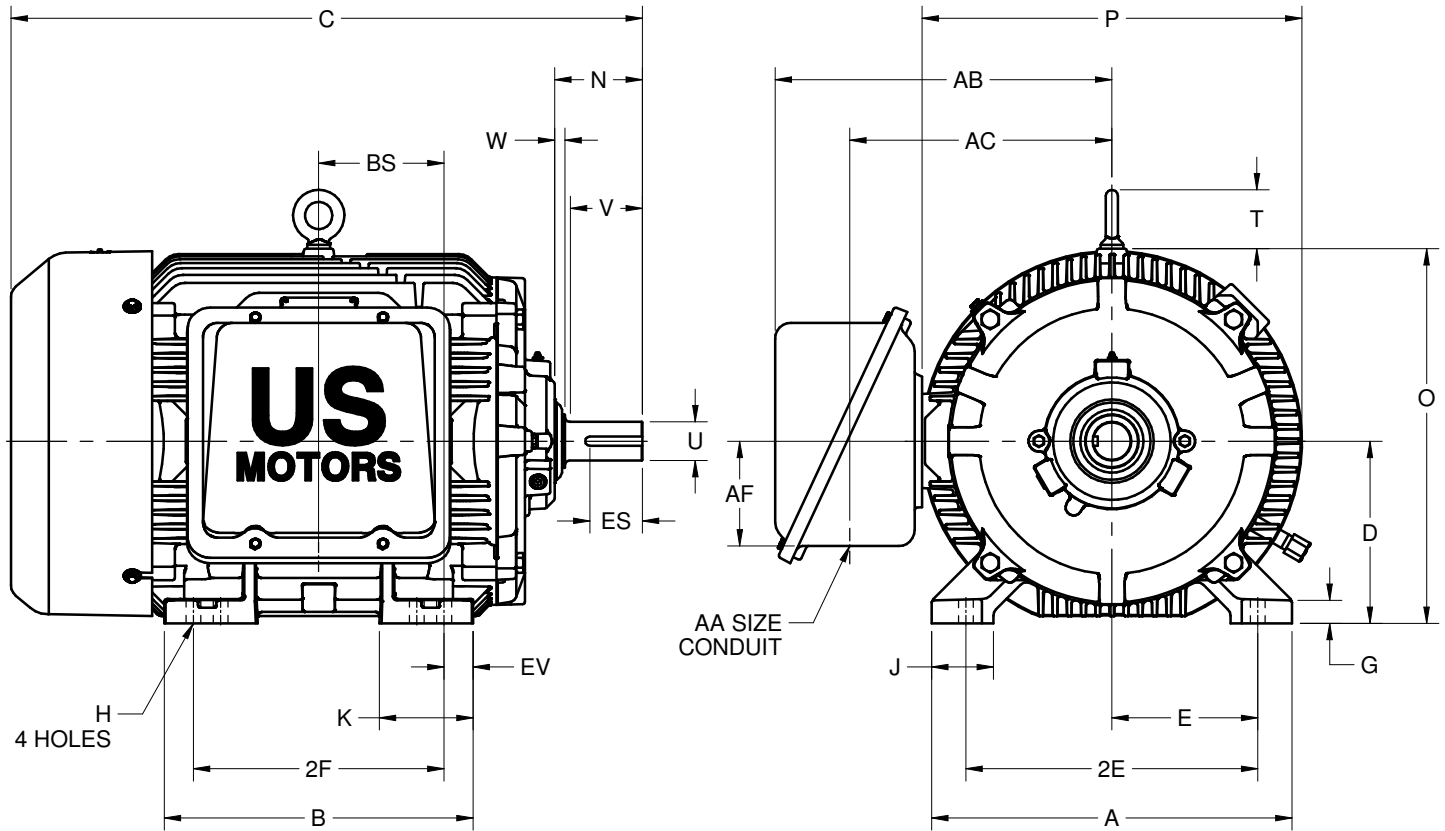

ALL DIMENSIONS ARE IN INCHES AND MILLIMETERS

UNITS	A	B	C	D -.06	E	2E ±.03	G	H +.05	J	K	N	O	P ²
IN	19.75	16.94	34.63	10.00	8.00	16.00	1.25	.81	3.38	5.13	4.81	20.56	21.13
MM	502	430	880	254	203	406	32	21	86	130	122	522	537

UNITS	T	U -.001	V MIN	W	AA	AB	AC	AF	BA	BS	EV	ES MIN	SQ KEY
IN	3.22	2.125	4.00	.56	3 NPT	18.47	14.38	5.75	6.62	6.88	1.59	2.78	.500
MM	82	53.98	102	14		469	365	146	168	175	40	71	12.70

FRAME	UNITS	2F ±.03
404TS	IN	12.25
	MM	311
405TS	IN	13.75
	MM	349

1. DIMENSIONS MAY VARY .25" DUE TO CASTING AND/OR FABRICATION VARIATIONS
2. LARGEST MOTOR WIDTH
3. STANDARD ASSEMBLY POSITION F-1 IS SHOWN. F-2 IS PROVIDED WHEN SPECIFIED. CONDUIT OPENING MAY BE LOCATED IN STEPS OF 90° REGARDLESS OF THE LOCATION
4. TOLERANCES ARE SHOWN IN INCHES ONLY

08-1062-02/-

Nidec Motor Corporation
St. Louis, Missouri

INFORMATION DISCLOSED ON THIS DOCUMENT IS CONSIDERED PROPRIETARY AND SHALL NOT BE REPRODUCED OR DISCLOSED WITHOUT WRITTEN CONSENT OF NIDEC MOTOR CORPORATION



ISSUED BY
R. TIMMERMANN
 APPROVED BY
M. CULLEN

IHP_DP_NMCA (MAR-2011) SOLIDEDGE