

EFFECTIVE:
23-AUG-22

SUPERSEDES:
08-AUG-22

DIMENSION PRINT

WORLD MOTOR 841 PLUS WITH OVERSIZE OUTLET BOX

FRAME: 447T
BASIC TYPE: CE

PRINT:
08-1080

SHEET:
1 OF 1

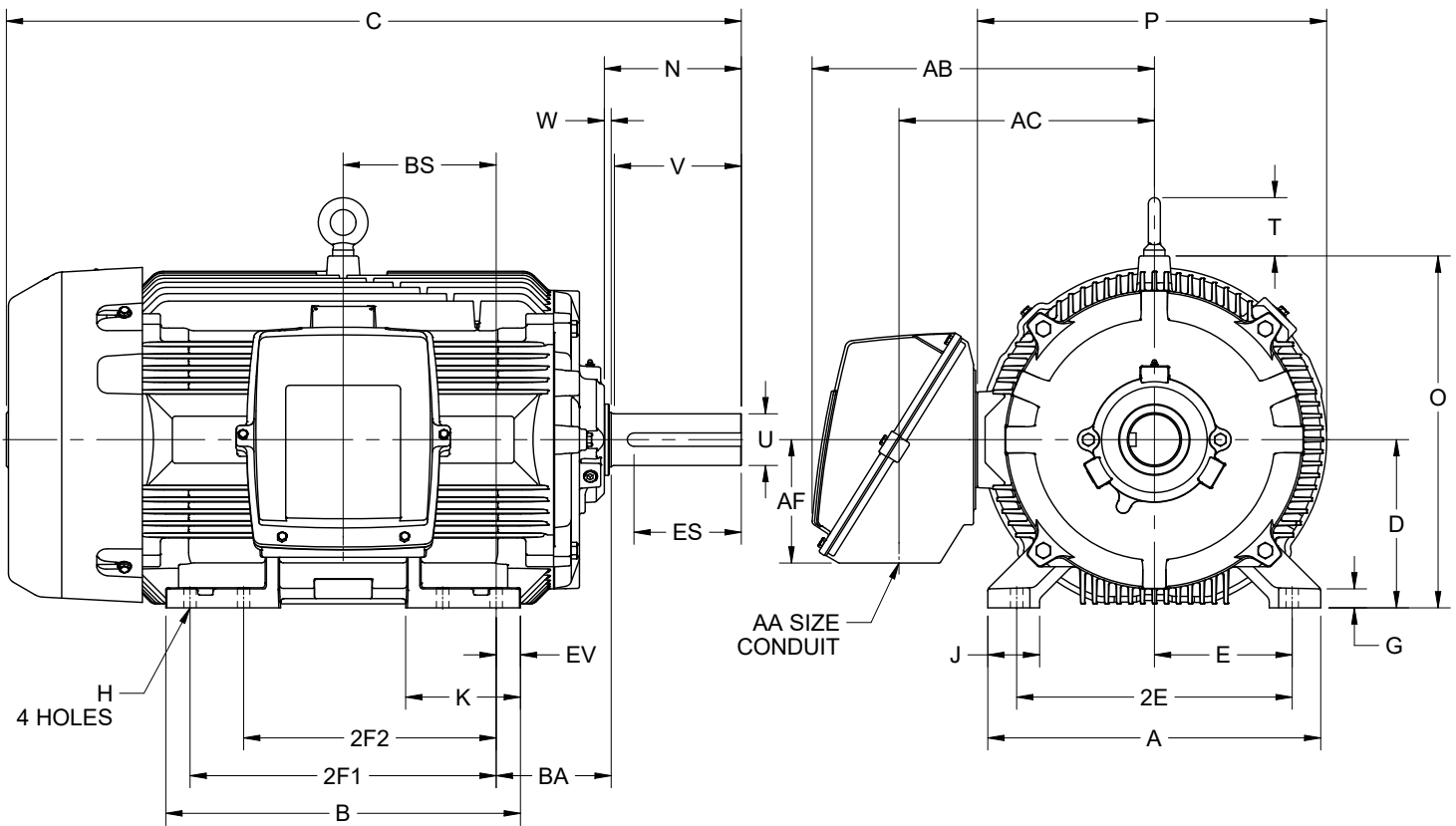

ALL DIMENSIONS ARE IN INCHES AND MILLIMETERS

UNITS	A	B	C	D -.06	E	2E ±.03	2F1 ±.03	2F2 ±.03	G	H +.05	J	K	N
IN	21.75	23.19	48.00	11.00	9.00	18.00	20.00	16.50	1.25	.81	3.38	7.50	8.94
MM	552	589	1219	279	229	457	508	419	32	21	86	191	227

UNITS	O	P ²	T	U -.001	V MIN	W	AA	AB	AC	AF	BA	BS	EV
IN	23.00	22.81	3.81	3.375	8.25	.44	3-1/2 NPT	22.38	16.69	8.06	7.50	10.00	1.59
MM	584	579	97	85.73	210	11		569	424	205	191	254	40

UNITS	ES MIN	SQ KEY
IN	6.91	.875
MM	176	22.23

1. DIMENSIONS MAY VARY .25" DUE TO CASTING AND/OR FABRICATION VARIATIONS
2. LARGEST MOTOR WIDTH
3. STANDARD ASSEMBLY POSITION F-1 IS SHOWN. F-2 IS PROVIDED WHEN SPECIFIED. CONDUIT OPENING MAY BE LOCATED IN STEPS OF 90° REGARDLESS OF THE LOCATION
4. TOLERANCES ARE SHOWN IN INCHES ONLY

08-1080/D

Nidec Motor Corporation
St. Louis, Missouri

INFORMATION DISCLOSED ON THIS DOCUMENT
IS CONSIDERED PROPRIETARY AND SHALL NOT BE
REPRODUCED OR DISCLOSED WITHOUT WRITTEN
CONSENT OF NIDEC MOTOR CORPORATION



ISSUED BY I. GONZALEZ
APPROVED BY G. GARCIA

IHP_DP_NMCA (MAR-2011) SOLIDEDGE