

EFFECTIVE:
24-AUG-20

SUPERSEDES:
05-SEP-19

DIMENSION PRINT

WORLD MOTOR INVERTER DUTY WITH SHROUD

FRAME: 447T
BASIC TYPE: CTI

PRINT:
08-1084-01

SHEET:
1 OF 1

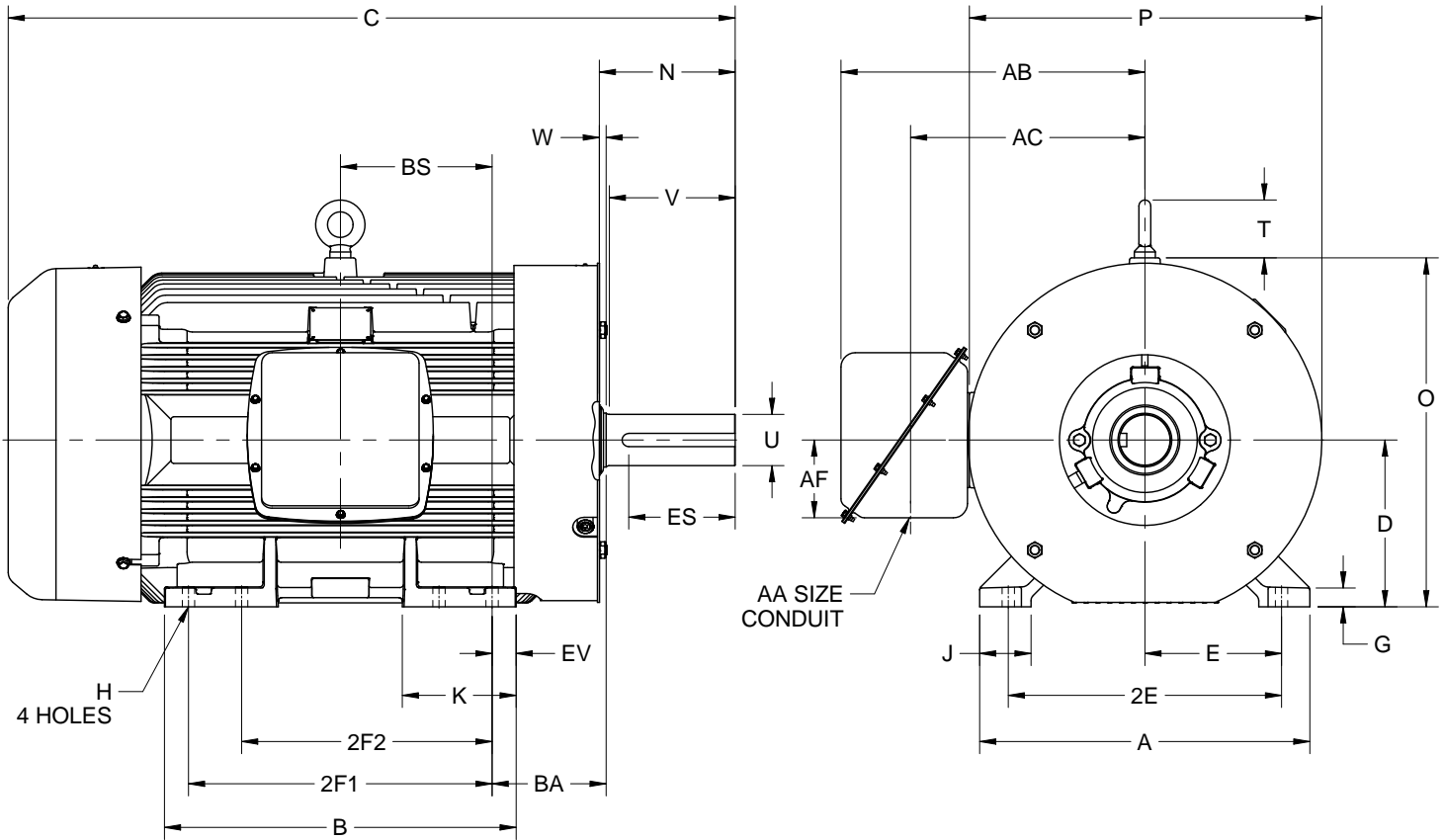

ALL DIMENSIONS ARE IN INCHES AND MILLIMETERS

UNITS	A	B	C	D -.06	E	2E ±.03	2F1 ±.03	2F2 ±.03	G	H +.05	J	K	N
IN	21.75	23.19	47.88	11.00	9.00	18.00	20.00	16.50	1.25	.81	3.38	7.50	8.94
MM	552	589	1216	279	229	457	508	419	32	21	86	191	227

UNITS	O	P ²	T	U -.001	V MIN	W	AA	AB	AC	AF	BA	BS	EV
IN	23.00	22.97	3.81	3.375	8.25	.44	3.00	20.03	15.44	5.13	7.50	10.00	1.59
MM	584	583	97	85.73	210	11		509	392	130	191	254	40

UNITS	ES MIN	SQ KEY
IN	6.91	.875
MM	176	22.23

1. DIMENSIONS MAY VARY .25" DUE TO CASTING AND/OR FABRICATION VARIATIONS
2. LARGEST MOTOR WIDTH
3. STANDARD ASSEMBLY POSITION F-1 IS SHOWN. F-2 IS PROVIDED WHEN SPECIFIED. CONDUIT OPENING MAY BE LOCATED IN STEPS OF 90° REGARDLESS OF THE LOCATION
4. TOLERANCES ARE SHOWN IN INCHES ONLY

08-1084-01/C

Nidec Motor Corporation
St. Louis, Missouri

INFORMATION DISCLOSED ON THIS DOCUMENT
IS CONSIDERED PROPRIETARY AND SHALL NOT BE
REPRODUCED OR DISCLOSED WITHOUT WRITTEN
CONSENT OF NIDEC MOTOR CORPORATION



ISSUED BY K. FRIEDMAN
APPROVED BY K. POTTER

IHP_DP_NMCA (MAR-2011) SOLIDEDGE