

EFFECTIVE:
18-DEC-18

DIMENSION PRINT
WORLD MOTOR COOLING TOWER WITH STEEL FAN COVER
FRAME: 364T, 365T
BASIC TYPE: TCI

PRINT:
08-1160

SUPERSEDES:
NEW

SHEET:
1 OF 1

F-2 ASSEMBLY POSITION

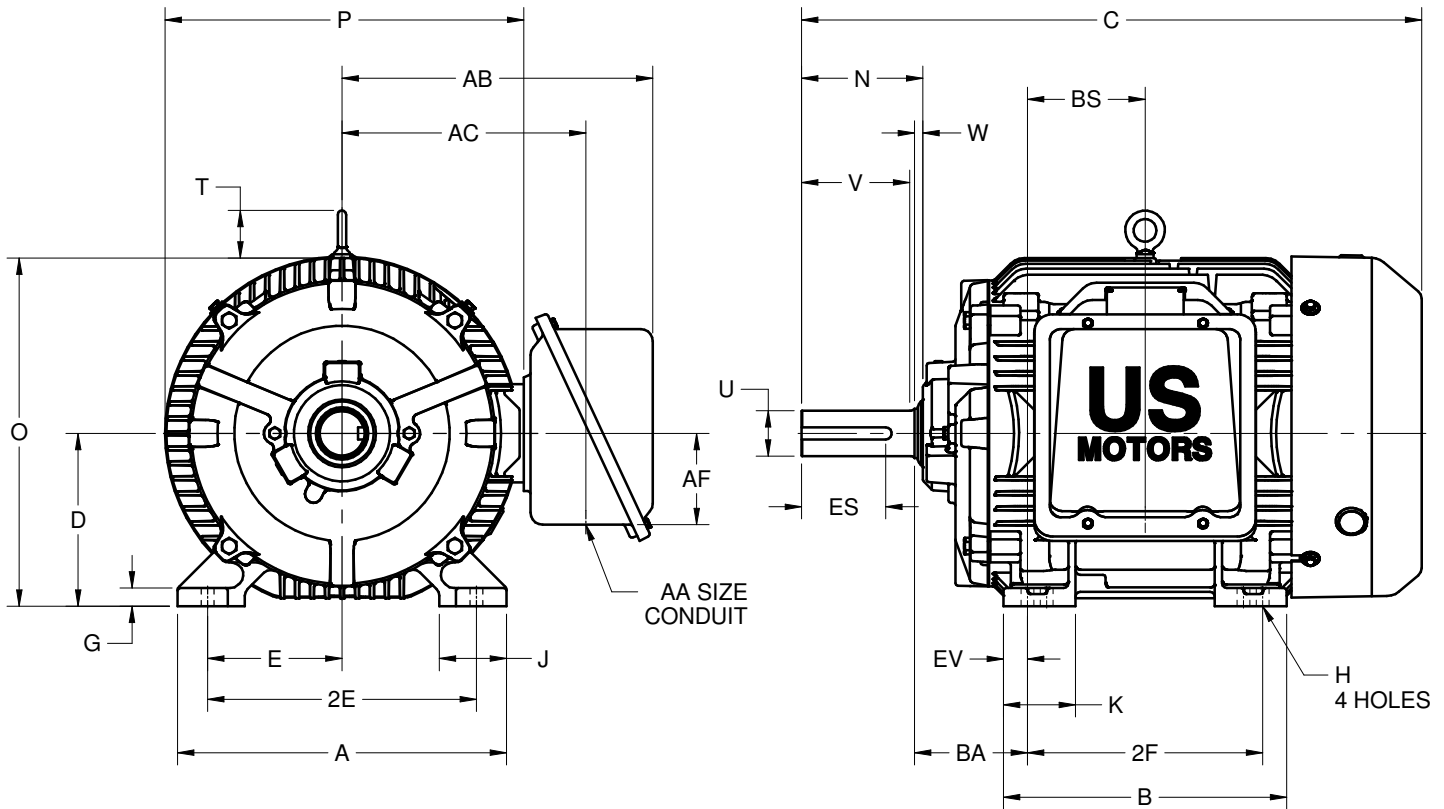

ALL DIMENSIONS ARE IN INCHES AND MILLIMETERS

UNITS	A	B	C	D -.06	E	2E ±.03	G	H +.05	J	K	N	O	P ²
IN	17.13	14.75	32.28	9.00	7.00	14.00	.94	.66	3.50	3.75	6.31	18.13	18.91
MM	435	375	820	229	178	356	24	17	89	95	160	461	480

UNITS	T	U -.001	V MIN	W	AA	AB	AC	AF	BA	BS	EV	ES MIN	SQ KEY
IN	2.47	2.375	5.62	.44	3 NPT	16.19	12.69	4.75	5.88	6.13	1.25	4.28	.625
MM	63	60.33	143	11		411	322	121	149	156	32	109	15.88

FRAME	UNITS	2F ±.03
364T	IN	11.25
	MM	286
365T	IN	12.25
	MM	311

1. DIMENSIONS MAY VARY .25" DUE TO CASTING AND/OR FABRICATION VARIATIONS
2. LARGEST MOTOR WIDTH
3. ASSEMBLY POSITION F-2 SHOWN. CONDUIT OPENING MAY BE LOCATED IN STEPS OF 90°
4. TOLERANCES ARE SHOWN IN INCHES ONLY

08-1160/-

Nidec Motor Corporation
St. Louis, Missouri

INFORMATION DISCLOSED ON THIS DOCUMENT IS CONSIDERED PROPRIETARY AND SHALL NOT BE REPRODUCED OR DISCLOSED WITHOUT WRITTEN CONSENT OF NIDEC MOTOR CORPORATION



ISSUED BY
R. TIMMERMANN
 APPROVED BY
M. CULLEN

IHP_DP_NMCA (MAR-2011) SOLIDEDGE