

EFFECTIVE:
09-JAN-19

SUPERSEDES:
NEW

DIMENSION PRINT
WORLD MOTOR COOLING TOWER
FRAME: 284T, 286T
BASIC TYPE: TCI

PRINT:
08-1162

SHEET:
1 OF 1

F-2 ASSEMBLY POSITION

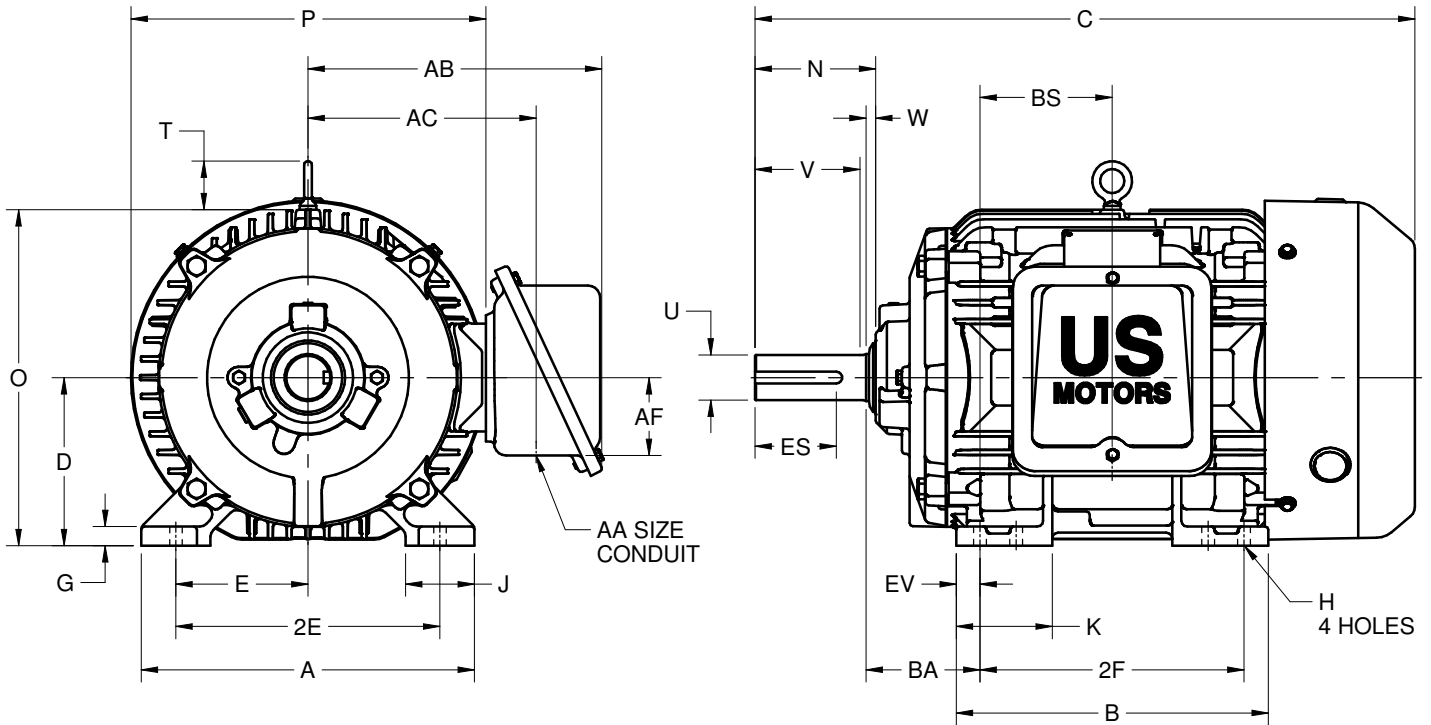

ALL DIMENSIONS ARE IN INCHES AND MILLIMETERS

UNITS	A	B	C	D -.06	E	2E ±.03	G	H +.05	J	K	N	O	P ²
IN	13.88	13.00	27.50	7.00	5.50	11.00	.78	.53	2.88	4.00	5.03	14.00	15.00
MM	353	330	699	178	140	279	20	13	73	102	128	356	381

UNITS	T	U -.001	V MIN	W	AA	AB	AC	AF	BA	BS	EV	ES MIN	SQ KEY
IN	2.03	1.875	4.38	.41	1-1/2 NPT	12.25	9.50	3.25	4.75	5.50	1.00	3.28	.500
MM	52	47.63	111	10		311	241	83	121	140	25	83	12.70

FRAME	UNITS	2F ±.03
284T	IN	9.50
	MM	241
286T	IN	11.00
	MM	279

1. DIMENSIONS MAY VARY .25" DUE TO CASTING AND/OR FABRICATION VARIATIONS
2. LARGEST MOTOR WIDTH
3. ASSEMBLY POSITION F-2 SHOWN. CONDUIT OPENING MAY BE LOCATED IN STEPS OF 90°
4. TOLERANCES ARE SHOWN IN INCHES ONLY

08-1162/-

Nidec Motor Corporation
St. Louis, Missouri

INFORMATION DISCLOSED ON THIS DOCUMENT IS CONSIDERED PROPRIETARY AND SHALL NOT BE REPRODUCED OR DISCLOSED WITHOUT WRITTEN CONSENT OF NIDEC MOTOR CORPORATION



ISSUED BY
R. TIMMERMANN
APPROVED BY
M. CULLEN

IHP_DP_NMCA (MAR-2011) SOLIDEDGE