

EFFECTIVE:
05-JUN-19

DIMENSION PRINT
WORLD MOTOR AUTO DUTY
FRAME: 182, 184
BASIC TYPE: JDE

PRINT:
08-1207

SUPERSEDES:
NEW

SHEET:
1 OF 1

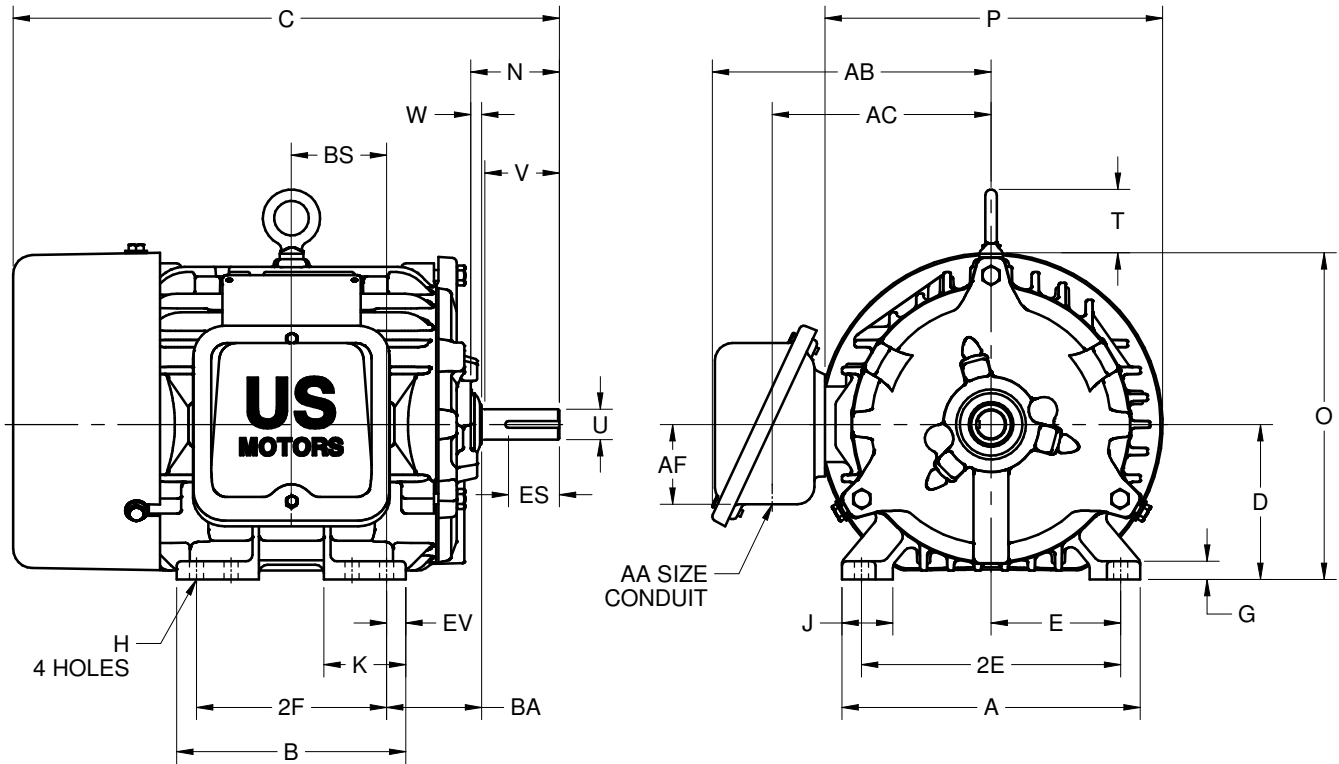

ALL DIMENSIONS ARE IN INCHES AND MILLIMETERS

UNITS	A	B	C	D -.06	E	2E ±.03	G	H +.05	J	K	N	O	P ²
IN	8.63	6.63	15.81	4.50	3.75	7.50	.53	.41	1.47	2.38	2.56	9.44	10.00
MM	219	168	402	114	95	191	13	10	37	60	65	240	254

UNITS	T	U -.0005	V MIN	W	AA	AB	AC	AF	BA	BS	EV	ES MIN	SQ KEY
IN	1.84	.8750	2.00	.31	3/4 NPT	8.06	6.34	2.31	2.75	2.75	.56	1.53	.188
MM	47	22.225	51	8		205	161	59	70	70	14	39	4.78

FRAME	UNITS	2F ±.03
182	IN	4.50
	MM	114
184	IN	5.50
	MM	140

1. DIMENSIONS MAY VARY .25" DUE TO CASTING AND/OR FABRICATION VARIATIONS
2. LARGEST MOTOR WIDTH
3. STANDARD ASSEMBLY POSITION F-1 IS SHOWN. F-2 IS PROVIDED WHEN SPECIFIED. CONDUIT OPENING MAY BE LOCATED IN STEPS OF 90° REGARDLESS OF THE LOCATION
4. TOLERANCES ARE SHOWN IN INCHES ONLY

08-1207/-

Nidec Motor Corporation
St. Louis, Missouri

INFORMATION DISCLOSED ON THIS DOCUMENT IS CONSIDERED PROPRIETARY AND SHALL NOT BE REPRODUCED OR DISCLOSED WITHOUT WRITTEN CONSENT OF NIDEC MOTOR CORPORATION



ISSUED BY
L. ARROYO
APPROVED BY
G. GARCIA

IHP_DP_NMCA (MAR-2011) SOLIDEDGE