

EFFECTIVE:  
**01-MAR-21**

SUPERSEDES:  
**10-JUN-20**

# DIMENSION PRINT

## WORLD MOTOR CORRODUTY

FRAME: 449T  
BASIC TYPE: TC

PRINT:  
**08-1250**

SHEET:  
**1 OF 1**

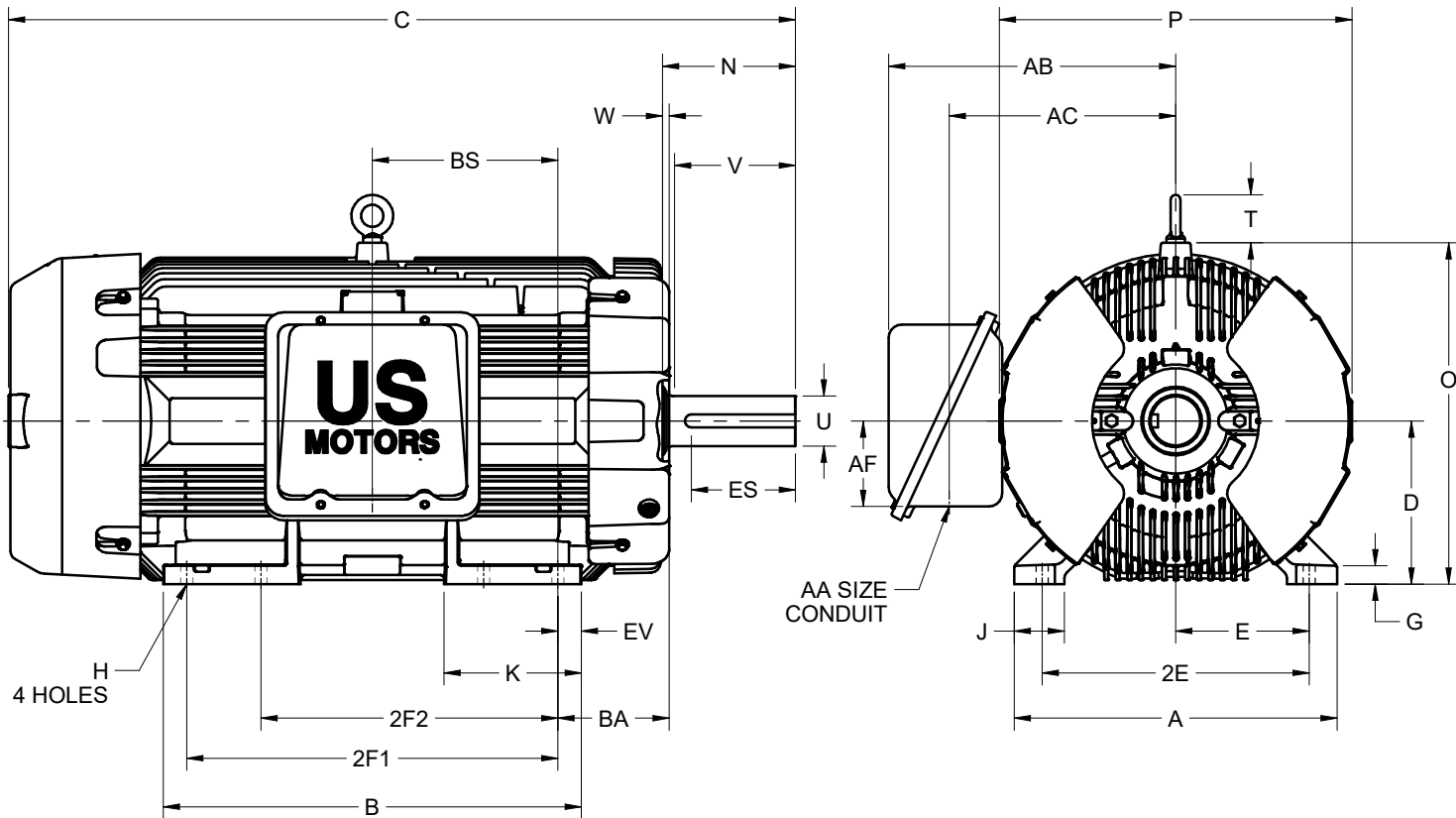

ALL DIMENSIONS ARE IN INCHES AND MILLIMETERS

UNITS	A	B	C	D -.06	E	2E ±.03	2F1 ±.03	2F2 ±.03	G	H +.05	J	K	N
IN	21.75	28.19	53.00	11.00	9.00	18.00	25.00	20.00	1.25	.81	3.38	9.25	8.94
MM	552	716	1346	279	229	457	635	508	32	21	86	235	227

UNITS	O	P <sup>2</sup>	T	U -.001	V MIN	W	AA	AB	AC	AF	BA	BS	EV
IN	23.00	23.78	3.25	3.375	8.25	.44	3 NPT	19.34	15.25	5.75	7.50	12.50	1.59
MM	584	604	83	85.73	210	11		491	387	146	191	318	40

UNITS	ES MIN	SQ KEY
IN	6.91	.875
MM	176	22.23

1. DIMENSIONS MAY VARY .25" DUE TO CASTING AND/OR FABRICATION VARIATIONS
2. LARGEST MOTOR WIDTH
3. STANDARD ASSEMBLY POSITION F-1 IS SHOWN. F-2 IS PROVIDED WHEN SPECIFIED. CONDUIT OPENING MAY BE LOCATED IN STEPS OF 90° REGARDLESS OF THE LOCATION
4. TOLERANCES ARE SHOWN IN INCHES ONLY

08-1250/A

**Nidec Motor Corporation**  
St. Louis, Missouri

INFORMATION DISCLOSED ON THIS DOCUMENT  
IS CONSIDERED PROPRIETARY AND SHALL NOT BE  
REPRODUCED OR DISCLOSED WITHOUT WRITTEN  
CONSENT OF NIDEC MOTOR CORPORATION



ISSUED BY  
**R. TIMMERMANN**  
APPROVED BY  
**T. MIDDLETON**

IHP\_DP\_NMCA (MAR-2011) SOLIDEDGE