

EFFECTIVE:  
**13-JAN-22**

SUPERSEDES:  
**18-AUG-20**

**DIMENSION PRINT**  
IEC WORLD MOTOR HOSTILE DUTY B5 FLANGE  
FRAME: 200  
BASIC TYPE: ICTEF

PRINT:  
**08-1261**

SHEET:  
**1 OF 1**

DIMENSIONS ARE SHOWN IN mm

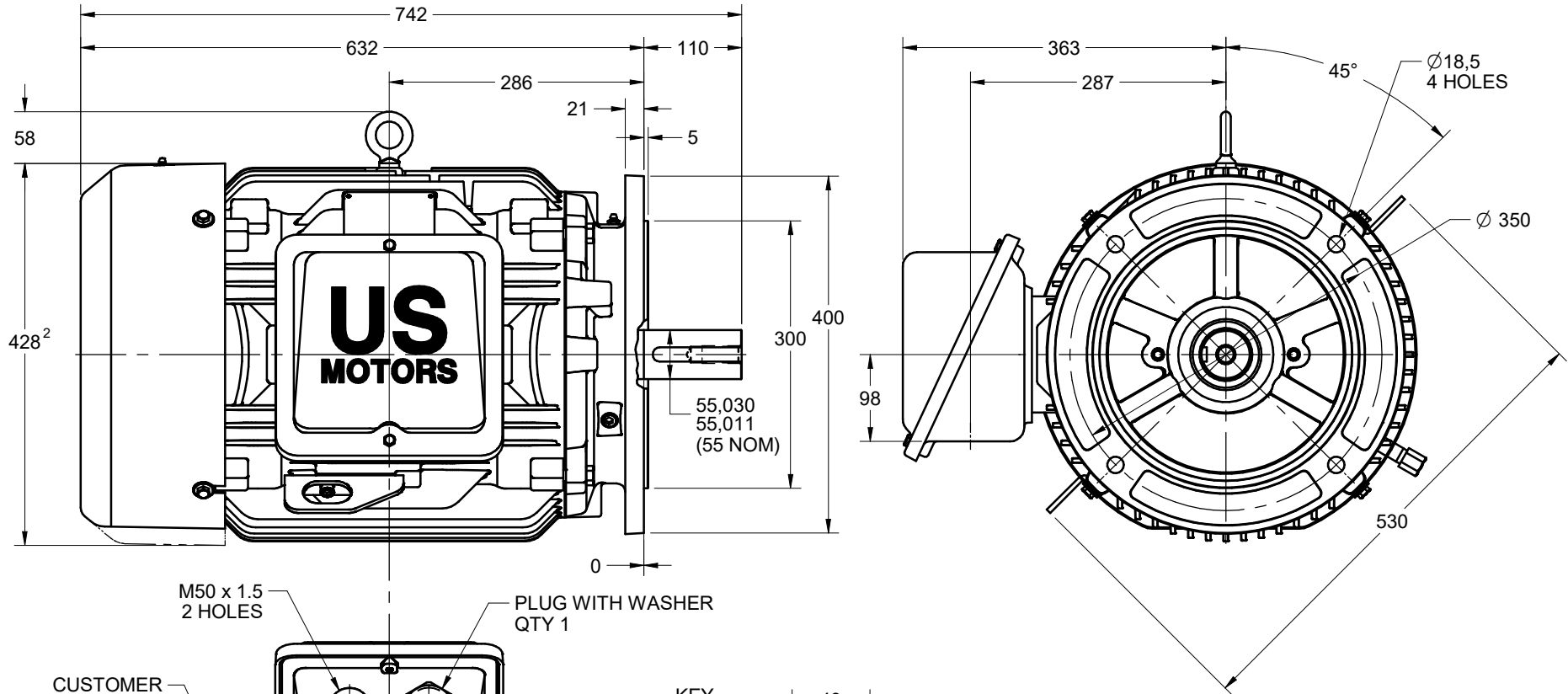

M50 x 1.5  
2 HOLES

PLUG WITH WASHER  
QTY 1

CUSTOMER  
MOUNTING  
FACE

33,07

SEE NOTE 4

89

KEY  
(90 LONG)

16

10

49

M20 x 2.5  $\nabla$  45

(55)

**TOLERANCES**

FACE RUNOUT	0,125 TIR
PERMISSIBLE ECCENTRICITY OF MOUNTING RABBET	0,125 TIR
PERMISSIBLE SHAFT RUNOUT	0,060 TIR

1. DIMENSIONS MAY VARY 6.4mm DUE TO CASTING AND/OR FABRICATION VARIATIONS
2. LARGEST MOTOR WIDTH
3. CONDUIT OPENING MAY BE LOCATED IN STEPS OF 90° REGARDLESS OF THE LOCATION
4. FOR BEST RESULTS, STUD OFFERED INTO EACH OF THE B5 MOUNTING HOLES SHOULD EXTEND APPROXIMATELY 41mm FROM CUSTOMER MOUNTING FACE

CUSTOMER MOUNTING  
CONDITION

08-1261/A

**Nidec Motor Corporation**  
St. Louis, Missouri

INFORMATION DISCLOSED ON THIS DOCUMENT  
IS CONSIDERED PROPRIETARY AND SHALL NOT BE  
REPRODUCED OR DISCLOSED WITHOUT WRITTEN  
CONSENT OF NIDEC MOTOR CORPORATION



ISSUED BY  
**R. TIMMERMANN**  
APPROVED BY  
**K. POTTER**

IHP\_DP\_IEC\_NMCA (JAN-2018) SOLIDEDGE