

EFFECTIVE:  
**13-SEP-21**

SUPERSEDES:  
**18-AUG-20**

**DIMENSION PRINT**  
IEC WORLD MOTOR HOSTILE DUTY B5 FLANGE (2 POLE)  
FRAME: 250  
BASIC TYPE: ICTE

PRINT:  
**08-1265**

SHEET:  
**1 OF 1**

DIMENSIONS ARE SHOWN IN mm

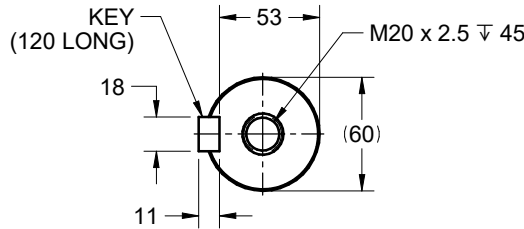
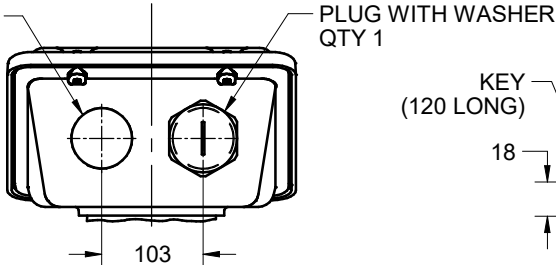
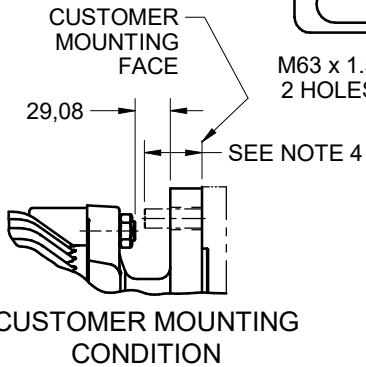
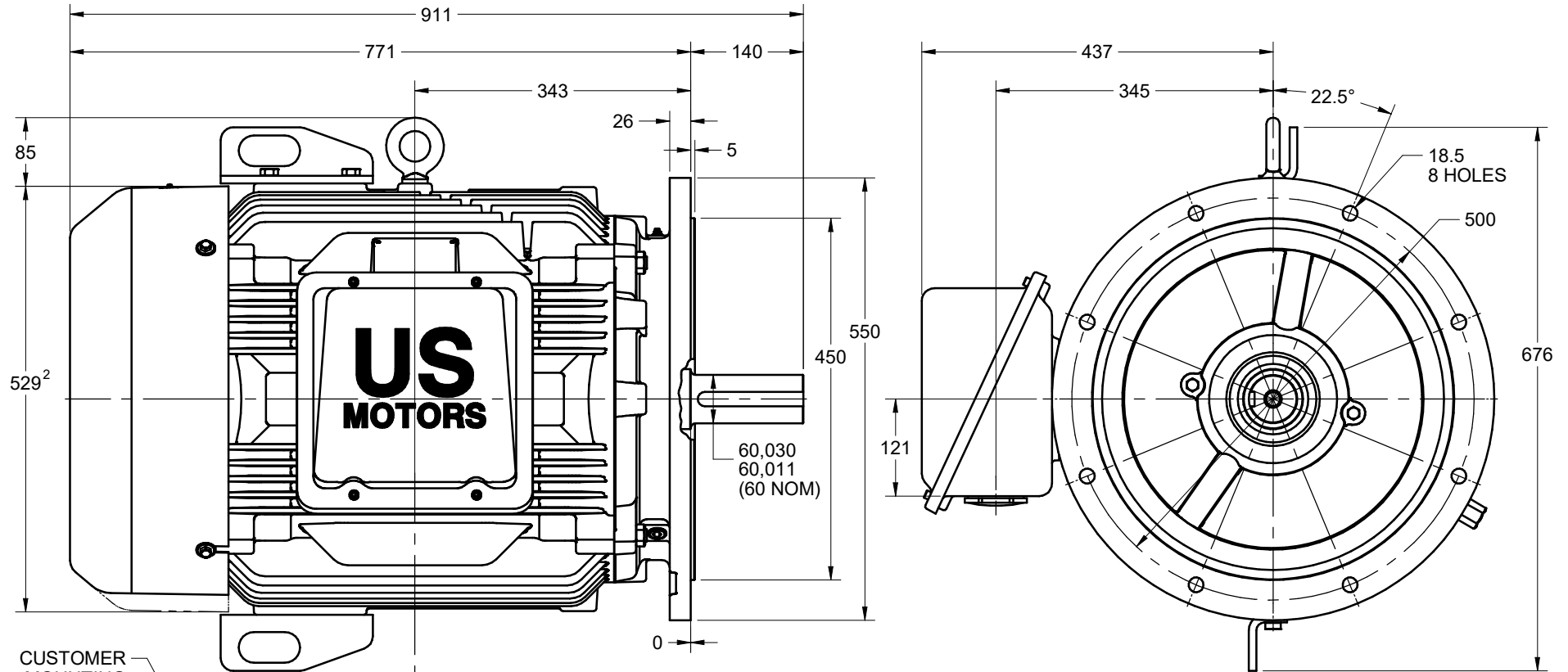

TOLERANCES	
FACE RUNOUT	0,125 TIR
PERMISSIBLE ECCENTRICITY OF MOUNTING RABBET	0,125 TIR
PERMISSIBLE SHAFT RUNOUT	0,060 TIR

- DIMENSIONS MAY VARY 6,4mm DUE TO CASTING AND/OR FABRICATION VARIATIONS
- LARGEST MOTOR WIDTH
- CONDUIT OPENING MAY BE LOCATED IN STEPS OF 90° REGARDLESS OF THE LOCATION
- FOR BEST RESULTS, STUD OFFERED INTO EACH OF THE B5 MOUNTING HOLES SHOULD EXTEND APPROXIMATELY 48mm FROM CUSTOMER MOUNTING FACE

08-1265/A

**Nidec Motor Corporation**  
St. Louis, Missouri

INFORMATION DISCLOSED ON THIS DOCUMENT IS CONSIDERED PROPRIETARY AND SHALL NOT BE REPRODUCED OR DISCLOSED WITHOUT WRITTEN CONSENT OF NIDEC MOTOR CORPORATION



ISSUED BY  
**R. TIMMERMANN**  
APPROVED BY  
**T. MIDDLETON**

IHP\_DP\_IEC\_NMCA (JAN-2018) SOLIDEDGE