

EFFECTIVE:
13-SEP-21

SUPERSEDES:
18-AUG-20

DIMENSION PRINT
IEC WORLD MOTOR HOSTILE DUTY B5 FLANGE (4 POLE AND SLOWER)
FRAME: 250
BASIC TYPE: ICTE

PRINT:
08-1266

SHEET:
1 OF 1

DIMENSIONS ARE SHOWN IN mm

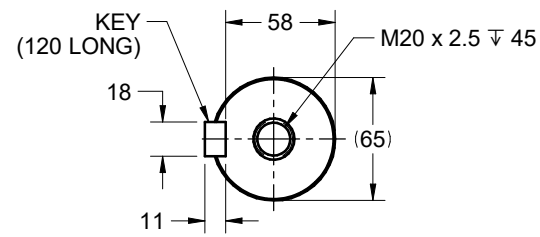
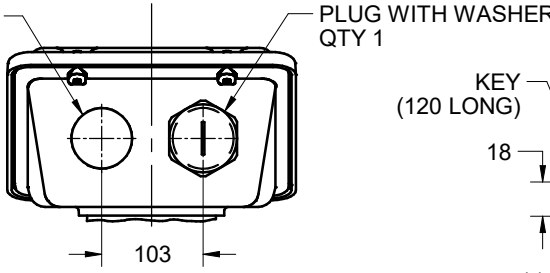
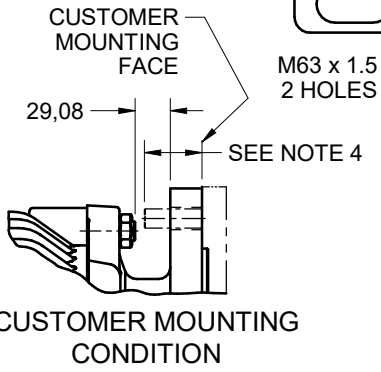
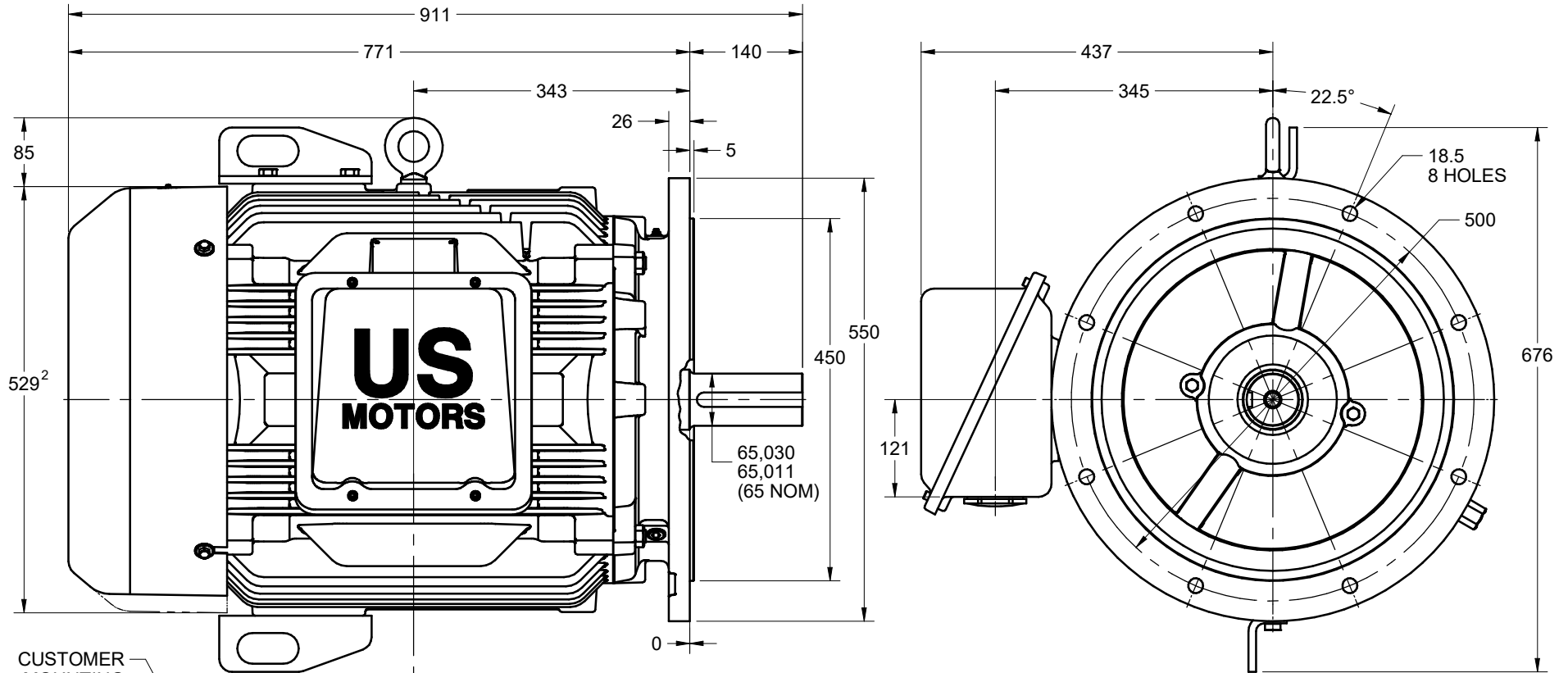

TOLERANCES	
FACE RUNOUT	0,125 TIR
PERMISSIBLE ECCENTRICITY OF MOUNTING RABBET	0,125 TIR
PERMISSIBLE SHAFT RUNOUT	0,060 TIR

- DIMENSIONS MAY VARY 6,4mm DUE TO CASTING AND/OR FABRICATION VARIATIONS
- LARGEST MOTOR WIDTH
- CONDUIT OPENING MAY BE LOCATED IN STEPS OF 90° REGARDLESS OF THE LOCATION
- FOR BEST RESULTS, STUD OFFERED INTO EACH OF THE B5 MOUNTING HOLES SHOULD EXTEND APPROXIMATELY 48mm FROM CUSTOMER MOUNTING FACE

08-1266/A

Nidec Motor Corporation
St. Louis, Missouri

INFORMATION DISCLOSED ON THIS DOCUMENT IS CONSIDERED PROPRIETARY AND SHALL NOT BE REPRODUCED OR DISCLOSED WITHOUT WRITTEN CONSENT OF NIDEC MOTOR CORPORATION



ISSUED BY
R. TIMMERMANN
APPROVED BY
T. MIDDLETON

IHP_DP_IEC_NMCA (JAN-2018) SOLIDEDGE