

EFFECTIVE:  
20-SEP-11

# VERTICAL MOTORS

## HOLLOWSHAFT STYLE "P" BASE

PRINT:  
09-1775

SUPERSEDES:  
20-JUL-11

FRAME: 449TP, TPH  
BASIC TYPE: HU, HUS

SHEET:  
1 OF 1

PUMP SHAFT, ADJUSTING NUT  
AND LOCKING SCREWS  
ARE NOT FURNISHED  
WITH MOTOR

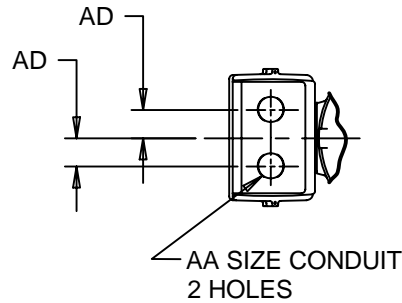
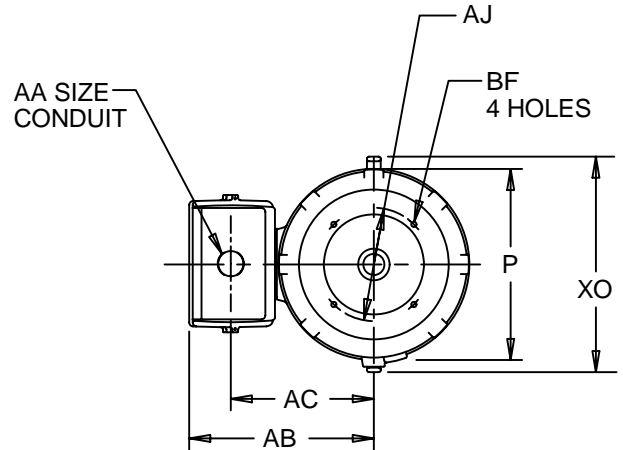
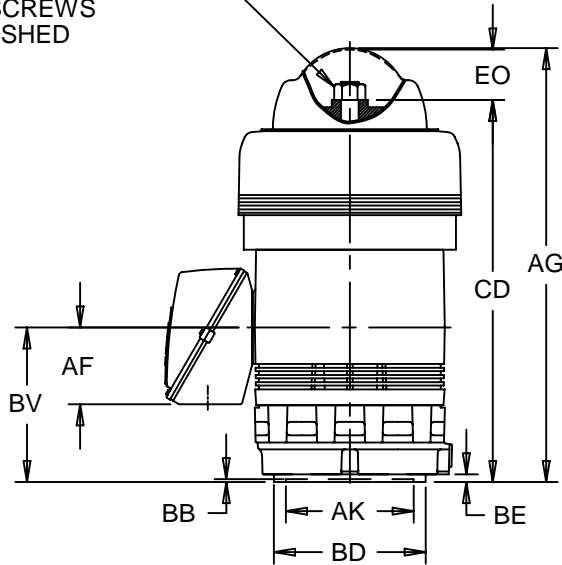

ALL DIMENSIONS ARE IN INCHES

FRAME	AJ	AK +.005	BD MAX	BF
449TP	14.750	13.500	24.50	.69
449TPH	14.750	13.500	20.00	.69

MAIN CONDUIT BOX	AA	AB	AC	AD	AF
SIZE 2.5	3 1/2 NPT	24.50	18.75	---	10.00
SIZE 3	3 1/2 NPT	28.00	20.88	3.00	10.94

P <sup>2</sup>	AG	BB MIN	BE	BV	CD	EO	XO
29.00	56.31	.25	.88	19.38	49.78	6.25	34.00

TOLERANCES	
FACE RUNOUT	.007 T.I.R.
PERMISSIBLE ECCENTRICITY OF MOUNTING RABBET	.007 T.I.R.

1: ALL ROUGH CASTING DIMENSIONS MAY VARY BY .25" DUE TO CASTING AND/OR FABRICATION VARIATIONS.  
2: LARGEST MOTOR WIDTH.

3: CONDUIT OPENING MAY BE LOCATED IN STEPS OF 90 DEGREES REGARDLESS OF LOCATION. STANDARD AS SHOWN WITH CONDUIT OPENING DOWN.

09-1775/B

**Nidec Motor Corporation**  
St. Louis, Missouri

INFORMATION DISCLOSED ON THIS DOCUMENT IS CONSIDERED PROPRIETARY AND SHALL NOT BE REPRODUCED OR DISCLOSED WITHOUT WRITTEN CONSENT OF NIDEC MOTOR CORPORATION



ISSUED BY  
**R. KING**  
APPROVED BY  
**J. O'BRIEN**

IHP\_DP\_NMCA (MAR-2011) SOLIDEDGE