

EFFECTIVE:
23-SEP-11

SUPERSEDES:
29-APR-11

VERTICAL MOTORS
TEFC - W/CAST IRON OUTLET BOX
FRAME: 320TP, TPH
BASIC TYPE: TU, TUC

PRINT:
09-2299-03

SHEET:
1 OF 1

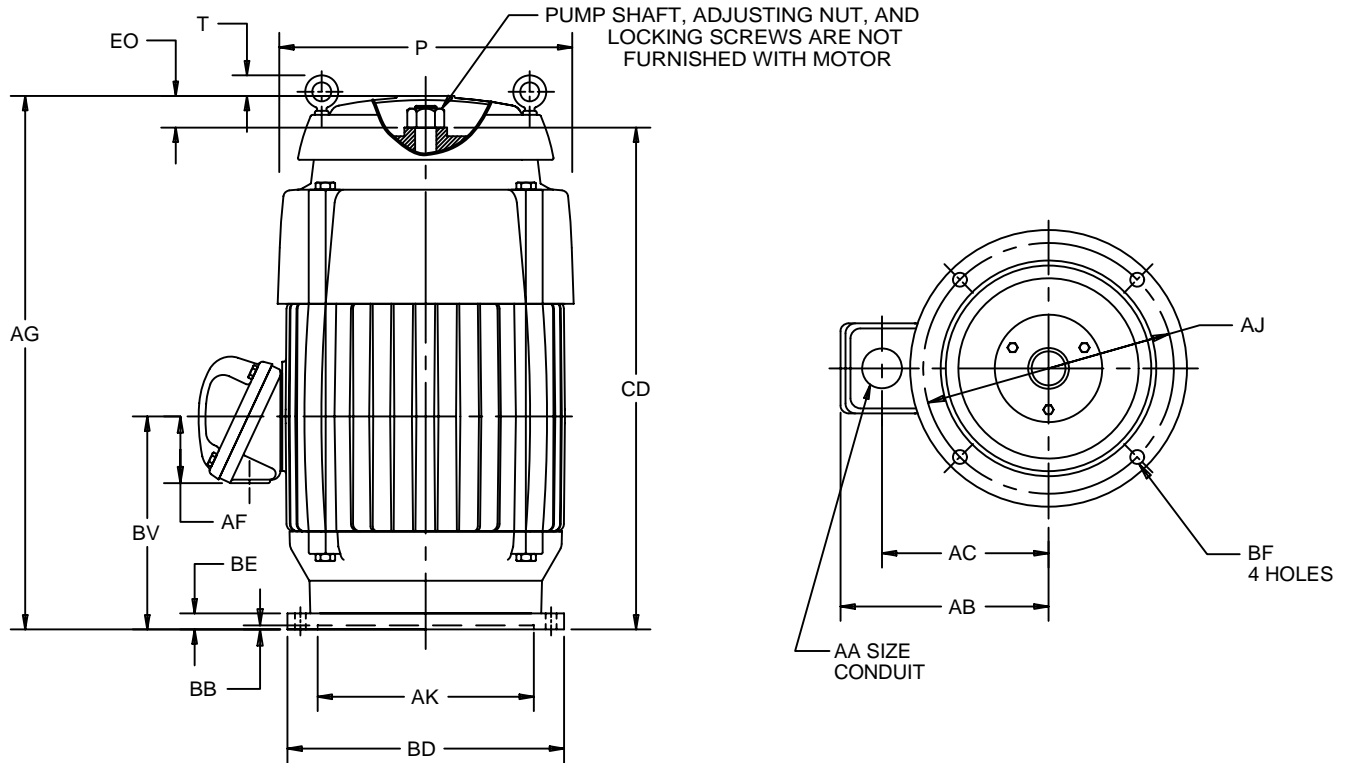

ALL DIMENSIONS ARE IN INCHES AND MILLIMETERS

UNITS	P ²	T ⁵	AA	AB	AC	AF	AG	BE	BV	CD	EO
IN	17.00	-1.25	2 NPT	14.25	10.75	3.25	35.63	1.00	11.94	28.50	6.88
MM	432	-32		362	273	83	905	25	303	724	175

FRAME	UNITS	AJ	AK	BB MIN	BD MAX	BF
320TP	IN	14.750	13.500	.25	16.50	.69
	MM	374.65	342.90	6	419	18
320TPH	IN	9.125	8.250	.19	12.00	.44
	MM	231.78	209.55	5	305	11

TOLERANCES	8.250 AK	13.500 AK
FACE RUNOUT	.004 T.I.R.	.007 T.I.R.
PERMISSIBLE ECCENTRICITY	.004 T.I.R.	.007 T.I.R.
OF MOUNTING RABBET		
"AK" DIMENSION	-.000;+.003	-.000;+.005

- 1: ALL ROUGH CASTING DIMENSIONS MAY VARY BY .25" (6mm) DUE TO CASTING AND/OR FABRICATION VARIATIONS.
- 2: LARGEST MOTOR WIDTH.
- 3: CONDUIT BOX MAY BE LOCATED ON EITHER SIDE OR ON TOP OF MOTOR. CONDUIT OPENINGS MAY BE LOCATED IN STEPS OF 90 DEGREES REGARDLESS OF LOCATION. STANDARD AS SHOWN WITH CONDUIT OPENING DOWN.

- 4: TOLERANCES SHOWN ARE IN INCHES.
- 5: (-) MINUS SIGN INDICATES EYEBOLT IS BELOW THE TOP OF THE UNIT.

09-2299/B

Nidec Motor Corporation
St. Louis, Missouri

INFORMATION DISCLOSED ON THIS DOCUMENT IS CONSIDERED PROPRIETARY AND SHALL NOT BE REPRODUCED OR DISCLOSED WITHOUT WRITTEN CONSENT OF NIDEC MOTOR CORPORATION



ISSUED BY
R. KING
APPROVED BY
K. POTTER

IHP_DP_NMCA (MAR-2011) SOLIDEDGE