

EFFECTIVE:
19-NOV-20

DIMENSION PRINT
WEATHER PROTECTED TYPE I
FRAME: 447TP, TPA, TPB
BASIC TYPE: RU

PRINT:
09-2628-51

SUPERSEDES:
16-OCT-14

SHEET:
1 OF 1

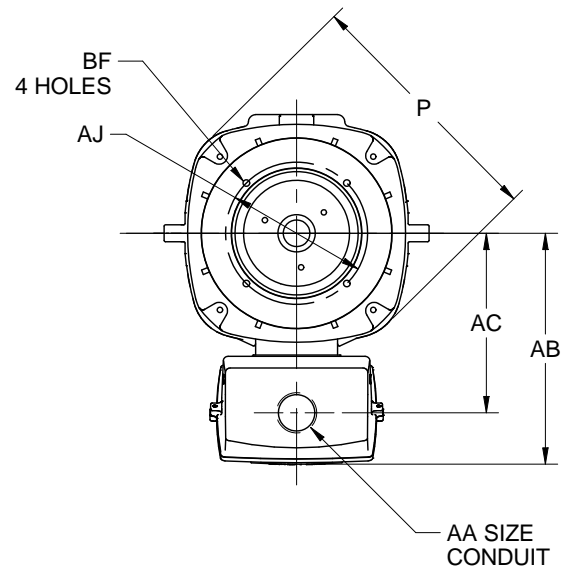
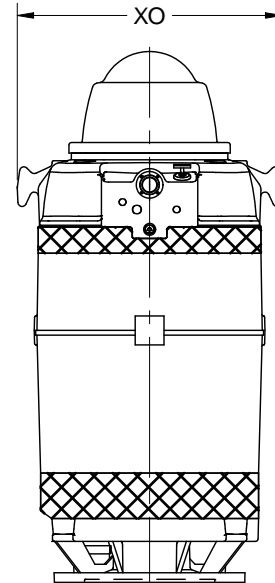
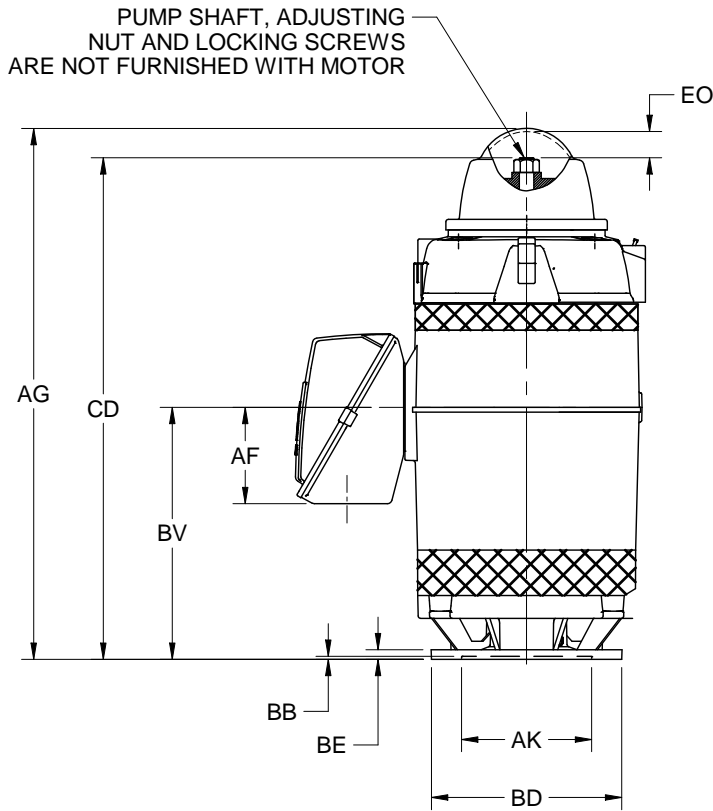

ALL DIMENSIONS ARE IN INCHES AND MILLIMETERS

FRAME	UNITS	BD MAX	AA	
447TP	IN	16.50	2 1/2 NPT	
	MM	419		
447TPA	IN	20.00		3 NPT
	MM	508		3 1/2 NPT
447TPB	IN	24.50	4 NPT	
	MM	622		

UNITS	P ²	AB	AC	AF	AG	AJ
IN	26.94	24.25	18.75	10.00	55.00	14.750
MM	684	616	476	254	1397	374.65

UNITS	AK +.005	BB MIN	BE	BF	BV	CD	EO	XO
IN	13.500	.25	1.00	.69	26.19	49.78	5.13	27.50
MM	342.90	6	25	18	665	1264	130	699

1. DIMENSIONS MAY VARY BY .25" DUE TO CASTING AND/OR FABRICATION VARIATIONS.
2. LARGEST MOTOR WIDTH.
3. TOLERANCES SHOWN ARE IN INCHES ONLY.

09-2628/E

Nidec Motor Corporation
St. Louis, Missouri

INFORMATION DISCLOSED ON THIS DOCUMENT IS CONSIDERED PROPRIETARY AND SHALL NOT BE REPRODUCED OR DISCLOSED WITHOUT WRITTEN CONSENT OF NIDEC MOTOR CORPORATION



ISSUED BY
D. CISNEROS
APPROVED BY
T. COLOMA

IHP_DP_NMCA (MAR-2011) SOLIDEDGE