

EFFECTIVE:
01-AUG-11

VERTICAL MOTORS

WEATHER PROTECTED TYPE I
FRAME: 5000VPH, VP, VPA
BASIC TYPE: RV

PRINT:
09-2661

SUPERSEDES:
03-JUL-06

SHEET:
1 OF 1

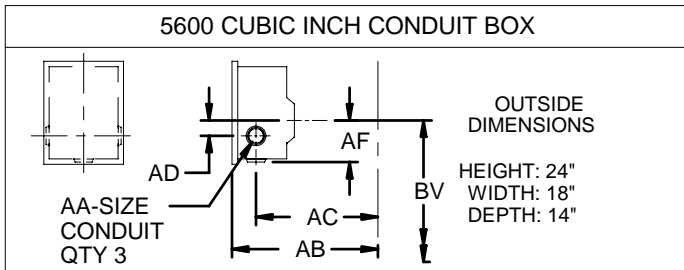
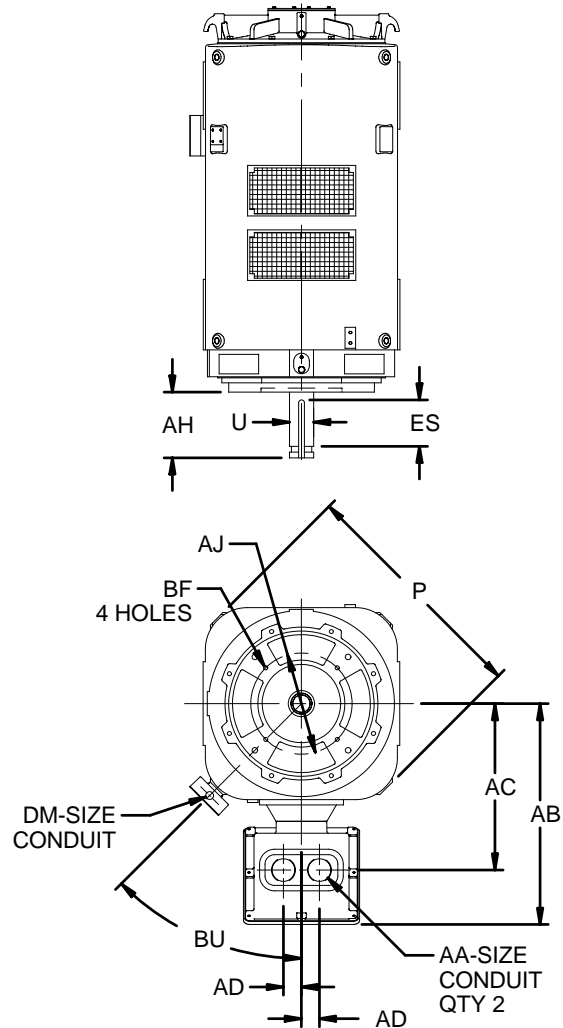
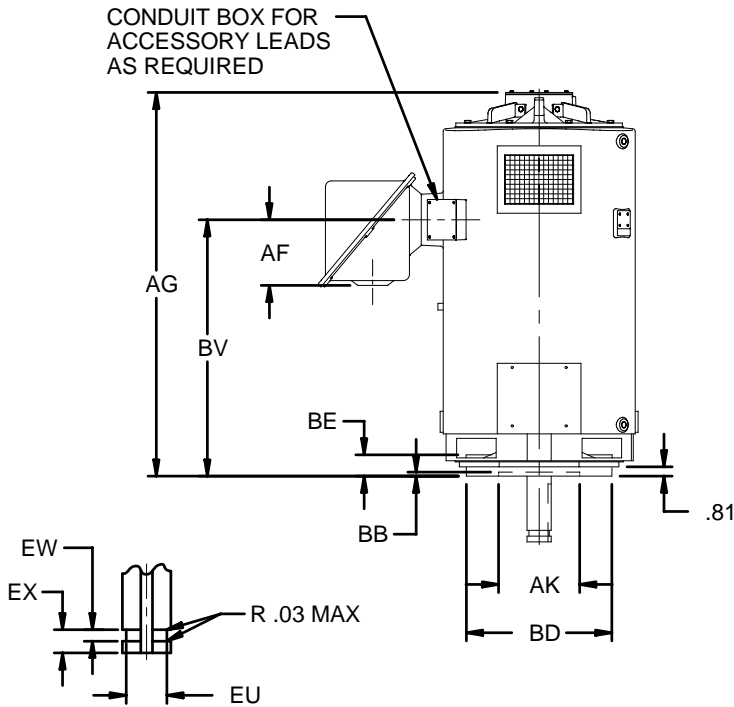

FRAME	P	AG	BV
5008	40.00	48.50	27.00
5012		63.50	42.00

POLE	U	AH	ES	EU	EW	EX	SQ
2	-0.001	±.062	MIN	-0.005	+0.002	-0.005	KEY
4 & SLOWER	3.125	7.000	5.00	2.625	.500	1.000	.750

VOLTS	C/BOX VOLUME (CU.IN.)	AB	AC	AD	AF	BU
0-4800	3400	36.50	27.88	3.00	10.94	45°
4801-6900	5600	36.13	30.13	4.00	10.81	

AA	DM
2 NPT	1/2 NPT
2-1/2 NPT	3/4 NPT
3 NPT	1 NPT
3-1/2 NPT	1-1/4 NPT
4 NPT	1-1/2 NPT

FRAME	AJ	AK	BB	BD	BE	BF
5000VPH	14.750	13.500	.25	20.00	2.19	.69
5000VP ³	14.750	13.500		24.50		.69
	22.000			.94		
5000VPA	26.000	22.000	30.50	.81		

TOLERANCES

FACE RUNOUT	.007 TIR
PERMISSIBLE ECCENTRICITY OF MOUNTING RABBET	.007 TIR
PERMISSIBLE SHAFT RUNOUT	.003 TIR
MAXIMUM SHAFT END PLAY	.010

1: DIMENSIONS MAY VARY .25" DUE TO CASTING AND/OR FABRICATION VARIATIONS.
2: DIMENSIONS AND TOLERANCES ARE SHOWN IN INCHES.
3: 5000VP HAS TWO BOLT CIRCLES.

Nidec Motor Corporation
St. Louis, Missouri

INFORMATION DISCLOSED ON THIS DOCUMENT IS CONSIDERED PROPRIETARY AND SHALL NOT BE REPRODUCED OR DISCLOSED WITHOUT WRITTEN CONSENT OF NIDEC MOTOR CORPORATION



ISSUED BY
R. TIMMERMANN
APPROVED BY
R. KING