

EFFECTIVE:
08-SEP-14

DIMENSION PRINT
TEFC, VERTICALLY MOUNTED

PRINT:
09-3125

SUPERSEDES:
16-JUL-14

FRAME: 400HP
BASIC TYPE: TVC

SHEET:
1 OF 1

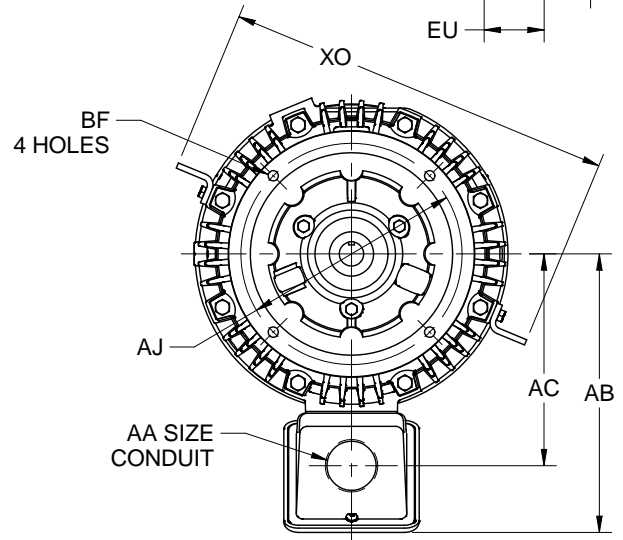
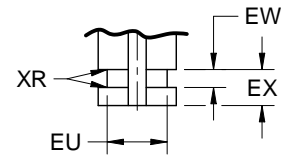
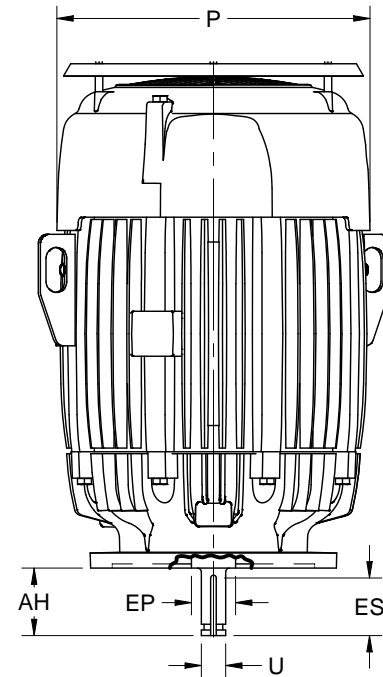
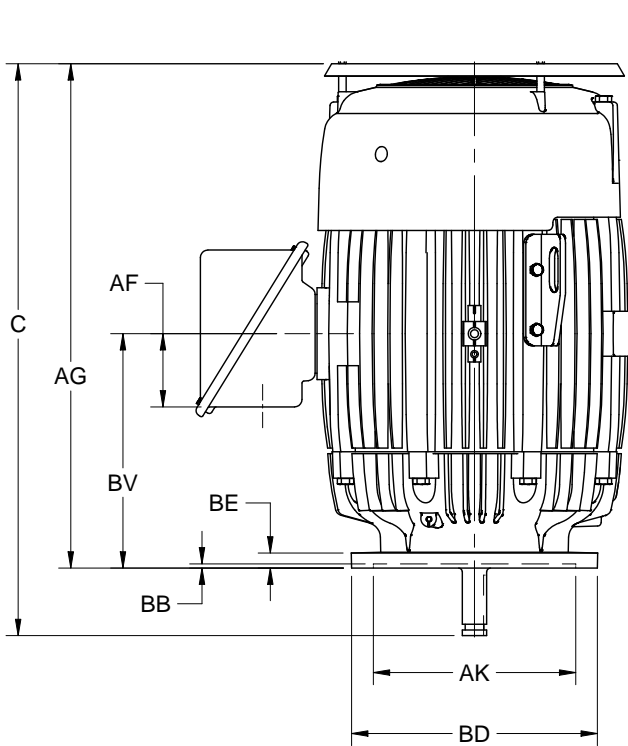

ALL DIMENSIONS ARE IN INCHES AND MILLIMETERS

UNITS	C	P ²	U -.0005	AA
IN	38.13	20.88	1.6250	3 NPT
MM	969	530	41.275	

UNITS	AB	AC	AF	AG	AH
IN	18.56	14.13	4.88	33.63	4.50
MM	472	359	124	854	114

UNITS	AJ	AK +.005	BB MIN	BD MAX	BE
IN	14.750	13.500	.25	16.50	1.00
MM	374.65	342.90	6	419	25

UNITS	BF	BV	EP MIN	ES MIN	EU -.005
IN	.69	15.63	2.250	3.03	1.125
MM	18	397	57	77	28.58

UNITS	EW +.002	EX -.005	SQ KEY	XO	XR
IN	.375	.750	.375	26.00	.03
MM	9.53	19.05	9.53	660	1

TOLERANCES	
FACE RUNOUT	.006 T.I.R.
PERMISSIBLE ECCENTRICITY OF MOUNTING RABBET	.006 T.I.R.
PERMISSIBLE SHAFT RUNOUT	.002 T.I.R.

1. DIMENSIONS MAY VARY BY .25" DUE TO CASTING AND/OR FABRICATION VARIATIONS.
2. LARGEST MOTOR WIDTH.
3. CONDUIT OPENING MAY BE LOCATED IN STEPS OF 90 DEGREES. STANDARD AS SHOWN WITH OPENING DOWN.
4. TOLERANCES SHOWN ARE IN INCHES ONLY.

09-3125/A

Nidec Motor Corporation
St. Louis, Missouri

INFORMATION DISCLOSED ON THIS DOCUMENT IS CONSIDERED PROPRIETARY AND SHALL NOT BE REPRODUCED OR DISCLOSED WITHOUT WRITTEN CONSENT OF NIDEC MOTOR CORPORATION



ISSUED BY
K. FRIEDMAN
APPROVED BY
J. WAIDMANN

IHP_DP_NMCA (MAR-2011) SOLIDEDGE