

EFFECTIVE:
25-FEB-16

SUPERSEDES:
NEW

DIMENSION PRINT
TOTALLY ENCLOSED FAN COOLED
FRAME: H210TP
BASIC TYPE: TUS

PRINT:
09-3242

SHEET:
1 OF 1

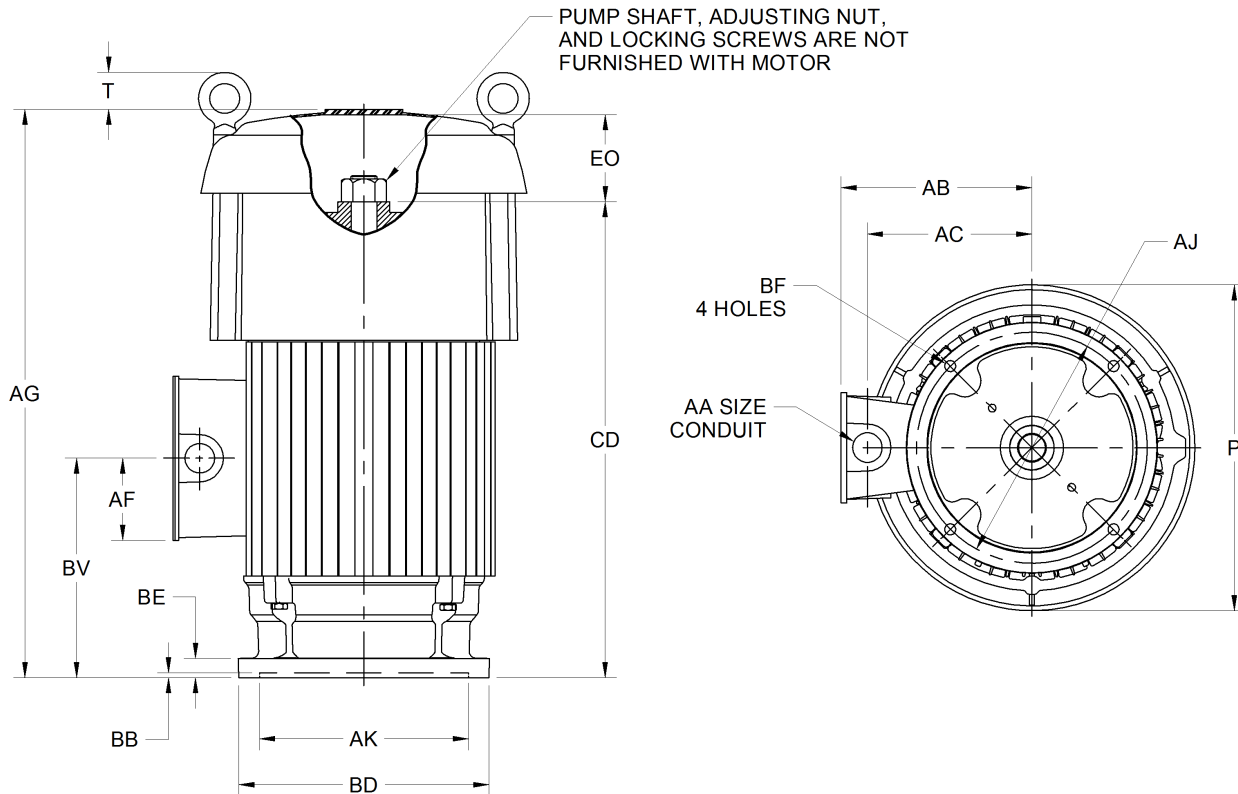

ALL DIMENSIONS ARE IN INCHES AND MILLIMETERS

UNITS	P ²	T	AA	AB	AC	AF	AG	AJ	AK +.003	BB MIN	BD MAX
IN	12.88	1.47	1.00	7.66	6.50	3.19	22.46	9.125	8.250	.19	10.00
MM	327	37		195	165	81	570	231.78	209.55	5	254

UNITS	BE	BF	BV	CD	EO
IN	.75	.44	8.38	18.81	3.00
MM	19	11	213	478	76

TOLERANCES	
FACE RUNOUT PERMISSIBLE	.004 T.I.R.
ECCENTRICITY	.004 T.I.R.
OF MOUNTING RABBET	.004 T.I.R.

- ALL ROUGH DIMENSIONS MAY VARY BY .25 IN DUE TO CASTING AND/OR FABRICATION VARIATIONS.
- LARGEST MOTOR WIDTH.
- CONDUIT OPENINGS MAY BE LOCATED IN STEPS OF 90 DEGREES REGARDLESS OF LOCATION. STANDARD AS SHOWN WITH CONDUIT OPENING DOWN.
- TOLERANCES SHOWN ARE IN INCHES ONLY.

Nidec Motor Corporation
St. Louis, Missouri

INFORMATION DISCLOSED ON THIS DOCUMENT IS CONSIDERED PROPRIETARY AND SHALL NOT BE REPRODUCED OR DISCLOSED WITHOUT WRITTEN CONSENT OF NIDEC MOTOR CORPORATION



ISSUED BY
G. MARTINEZ
APPROVED BY
G. GARCIA

IHP_DP_NMCA (MAR-2011) SOLIDEDGE