

EFFECTIVE:
17-SEP-18

DIMENSION PRINT
WEATHER PROTECTED TYPE II
FRAME: 449TPH, TP, TPA
BASIC TYPE: RU

PRINT:
09-3309

SUPERSEDES:
06-SEP-18

SHEET:
1 OF 1

PUMP SHAFT, ADJUSTING NUT AND LOCKING SCREWS ARE NOT FURNISHED WITH MOTOR

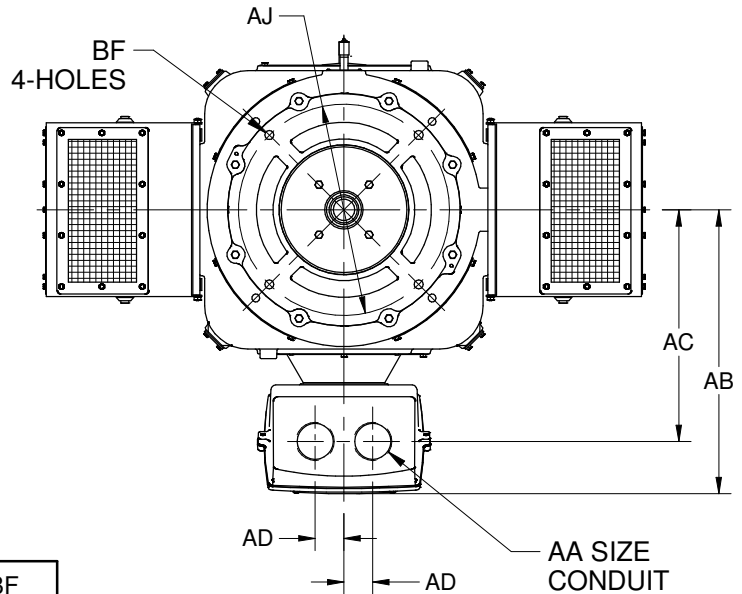
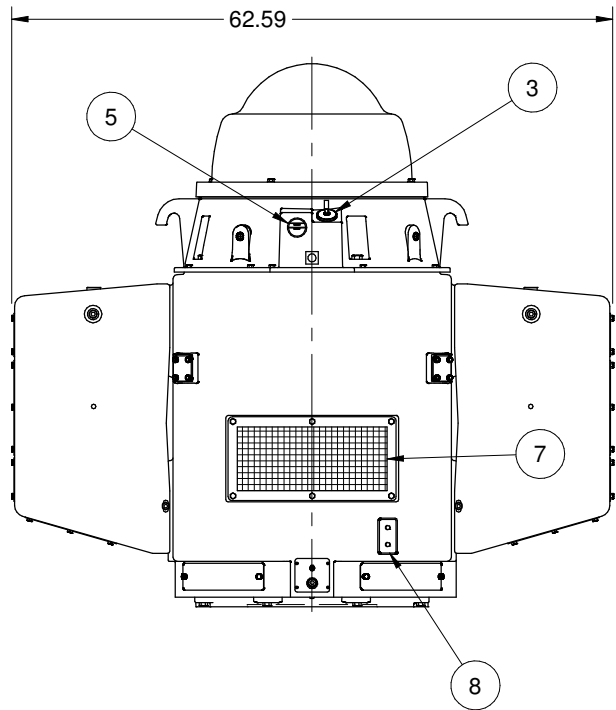
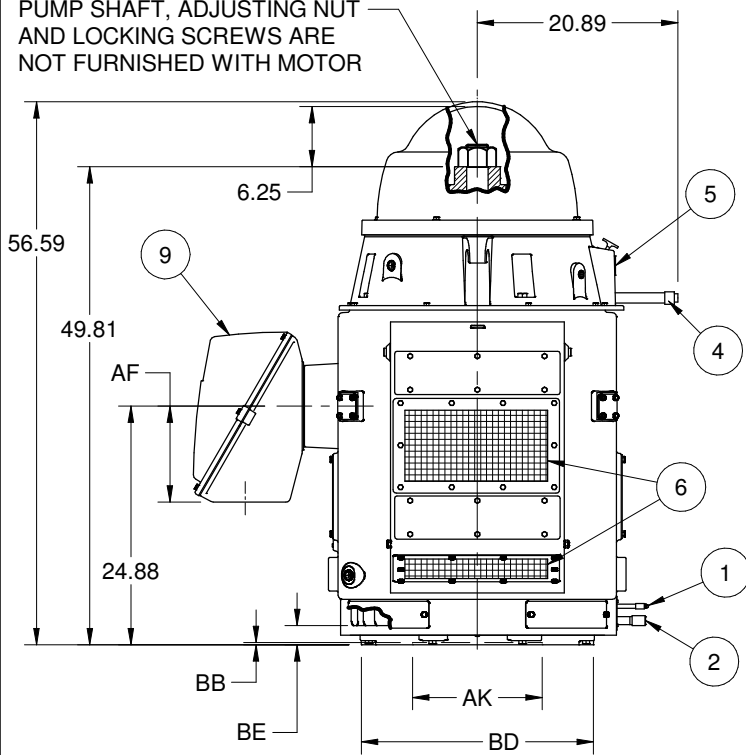

| AA |
|-----------|
| 2 NPT |
| 2 1/2 NPT |
| 3 NPT |
| 3 1/2 NPT |
| 4 NPT |

| C/BOX VOLUME (CU. IN.) | QTY OF CONDUIT HOLES | AB | AC | AD | AF |
|------------------------|----------------------|-------|-------|------|-------|
| 2000 | 2 | 29.63 | 24.13 | 3.50 | 10.00 |
| 3400 | 2 | 35.28 | 26.25 | 3.00 | 10.94 |

| FRAME | AJ | AK +.005 | BB MIN | BD MAX | BE | BF |
|---------|-------|----------|--------|--------|------|------|
| 449PH | 14.75 | 13.500 | .25 | 20.00 | 2.00 | .688 |
| 10 449P | 14.75 | 13.500 | | 24.50 | | .688 |
| | 22.00 | | | 30.50 | | .938 |
| 449PA | 26.00 | 22.000 | | | | .813 |

FEATURE LISTING

| | |
|---------------------------|------------------------------|
| 1 LOWER GREASE FILL | 6 AIR INTAKE, 180° APART |
| 2 LOWER GREASE DRAIN | 7 AIR EXHAUST, 180° APART |
| 3 UPPER SUMP OIL FILL | 8 GRD PADS, DIAG OPP, 1/2-13 |
| 4 UPPER SUMP OIL DRAIN | 9 MAIN CONDUIT BOX |
| 5 UPPER SUMP SIGHT WINDOW | 10 449P HAS TWO BOLT CIRCLES |

ALL DIMENSIONS ARE IN INCHES.

| TOLERANCES | |
|---|----------|
| FACE RUNOUT | .007 TIR |
| PERMISSIBLE ECCENTRICITY OF MOUNTING RABBET | .007 TIR |
| NON-MACHINED DIMENSIONS MAY VARY BY ±.25 | |

09-3309/G

Nidec Motor Corporation
St. Louis, Missouri

INFORMATION DISCLOSED ON THIS DOCUMENT IS CONSIDERED PROPRIETARY AND SHALL NOT BE REPRODUCED OR DISCLOSED WITHOUT WRITTEN CONSENT OF NIDEC MOTOR CORPORATION



ISSUED BY
R. KING
APPROVED BY
T. COLOMA

IHP_DP_NMCA (MAR-2011) SOLIDEDGE