

A  
A

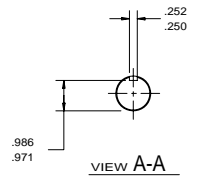
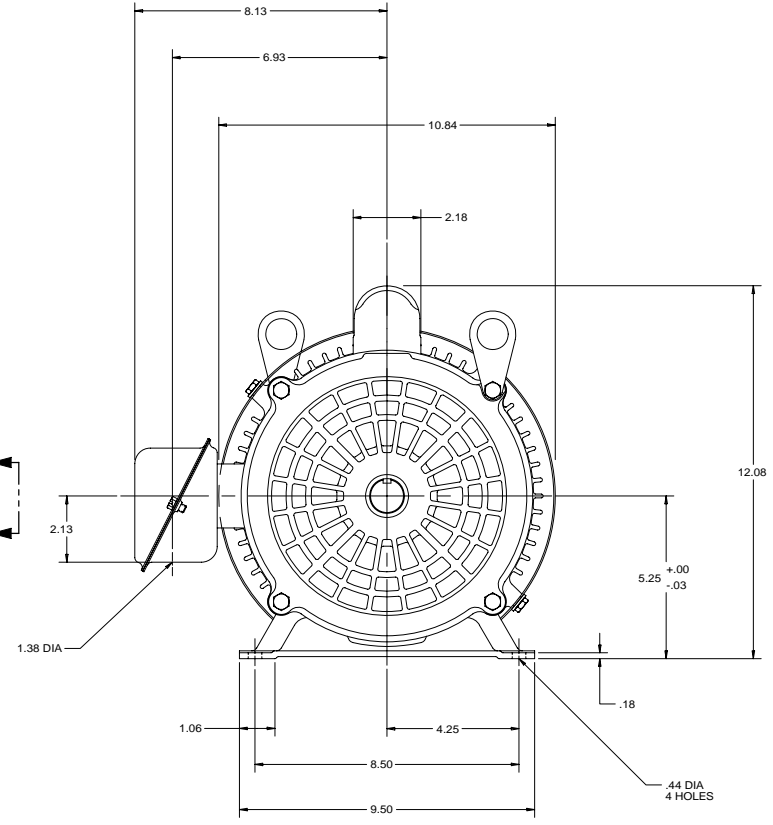

FRAME	TYPE	HP	RPM	PH	HZ	SF	VOLTS	AMPS
213	SM	2	1740	1	60	1.0	115/230	24.0/12.0

REVISION DESCRIPTION FOR: ECO A1000-50 UPDATED TO NIDEC FORMAT.		SCALE: NONE	UNITS: IN	TITLE: DRAWING, DIMENSION	NIDEC MOTOR CORPORATION
MATERIAL: ---		TOLERANCES ON DIMENSIONS (UNLESS OTHERWISE SPECIFIED): INCHES: mm		ISSUED BY: R. KING	
MUST BE COMPLIANT TO RoHS DIRECTIVE EU 2002/95/EC AND REGULATION EC 1907/2006/REACH AS AMENDED.		ANGLES: X° = ±1°		APPROVED BY: J. HAGENE	REVISION DATE: 28-SEP-11
				CODE: DP	DWG NO.: 0476449
				SHEET NUMBER: A	TOTAL SHEETS: 1 OF 1

NIDEC CONFIDENTIAL  
NIDEC MOTOR CORPORATION 28-Sep-11