

A
A

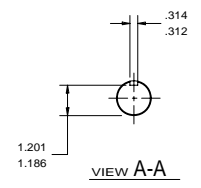
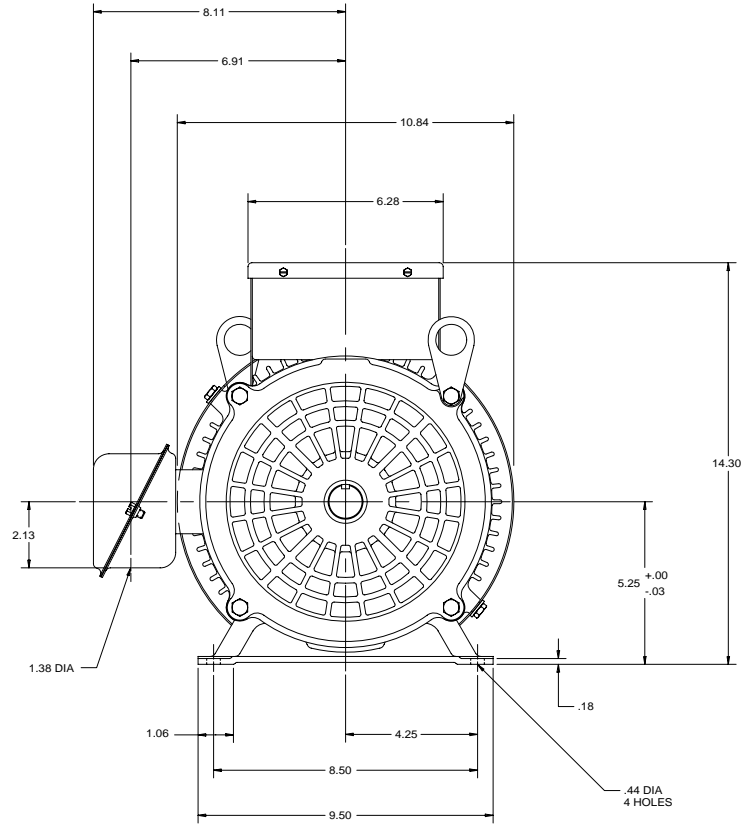

FRAME	TYPE	HP	RPM	PH	HZ	SF	VOLTS	AMPS
213T	SM	7.5	3480	1	60	1.0	230	30.3

REVISION DESCRIPTION FOR: ECO A1000-50 UPDATED TO NIDEC FORMAT.		SCALE: NONE	UNITS: IN	TITLE: DRAWING, DIMENSION	NIDEC MOTOR CORPORATION
TOLERANCES ON DIMENSIONS (UNLESS OTHERWISE SPECIFIED)					
MATERIAL:		INCHES	mm	ISSUED BY: R. KING	APPROVED BY: J. HAGENE
MUST BE COMPLIANT TO RoHS DIRECTIVE EU 2002/95/EC AND REGULATION EC 1907/2006/REACH AS AMENDED.		ANGLES X° = ±1°		REVISION DATE: 28-SEP-11	REV. NUMBER: A
		DP	0476475	1 OF 1	D

NIDEC CONFIDENTIAL
NIDEC MOTOR CORPORATION 28-Sep-11