

#16 GREEN GROUND LEAD  
TO BE 6.000±.250 BETWEEN  
CENTERS OF TERMS.  
TERM. TO FIT #10 SCREW

SUPPLIED DETACHED:  
1-CAPACITOR 5MFD 370V  
1-CAPACITOR CLAMP  
1-CAPACITOR CAP  
2-10-32 TYPE "C" SCREWS

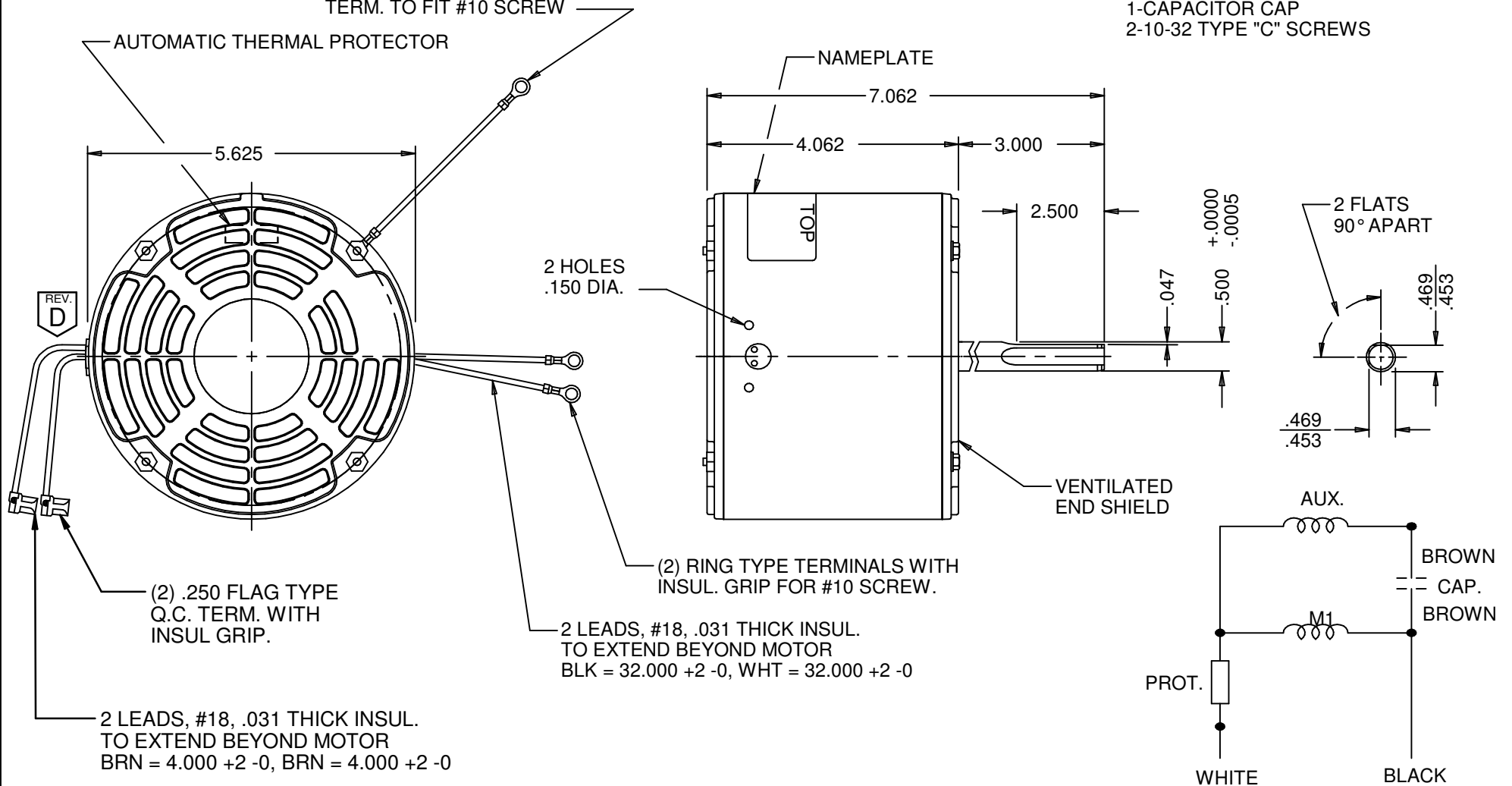

NIDEC MOTOR CORPORATION 03-Dec-18

MODEL	REF	CUSTOMER	HP	VOLTS	AMPS	HZ	RPM	ROTATION	CUSTOMER PN			
K55HXSK-7719	-	STANDARD	1/4	230	2.1	60	1550	CW LEAD END	6124			
SHEET NUMBER 1 OF 1		REV D		REVISION RECORD FOR: E33182			INFORMATION DISCLOSED ON THIS DOCUMENT IS CONSIDERED PROPRIETARY AND SHALL NOT BE REPRODUCED OR DISCLOSED WITHOUT WRITTEN CONSENT OF NIDEC MOTOR CORPORATION			<b>NIDEC MOTOR CORPORATION</b>		
REVISION DATE		LEAD EXIT RELOCATED AT 09:00 O'CLOCK.										
03-DEC-18												
ISSUED BY E. REYES			REVIEWED BY C. LUGO		ENGINEER APPROVED B. GAITAN		TITLE ASSEMBLED VIEW			CODE V01	ITEM NO. 244376	SIZE A