

12 LEADS, #18 GA. .031 THICK INSUL. TO EXTEND  
 5.000±1.000 BEYOND ENDSHIELD, END TO BE  
 SKINNED .750, LEADS TO BE NUMBERED  
 1,2,3,4,5,6,7,8,9,P4,P5 & P6

SHAFT KEY TAPPED TO MOTOR

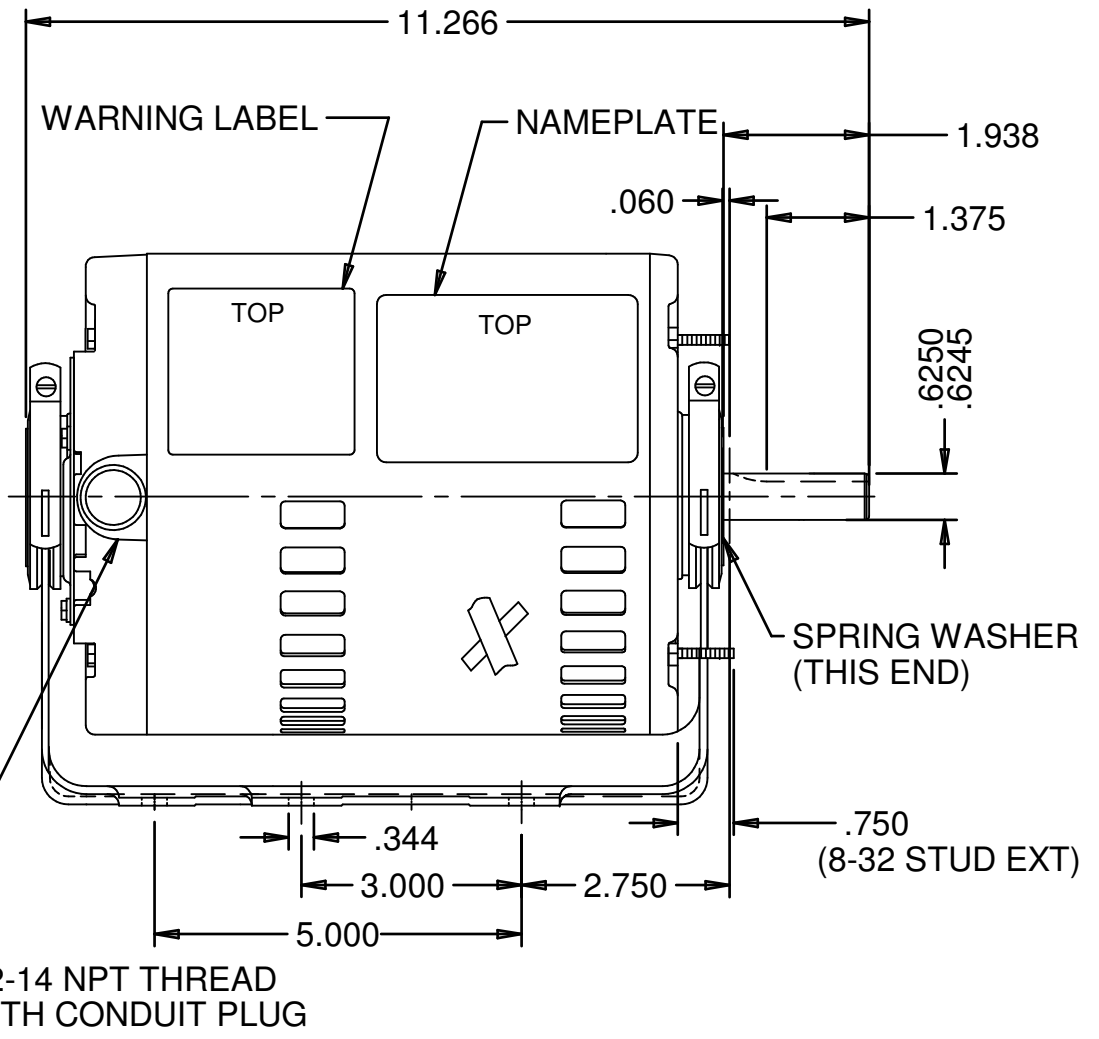
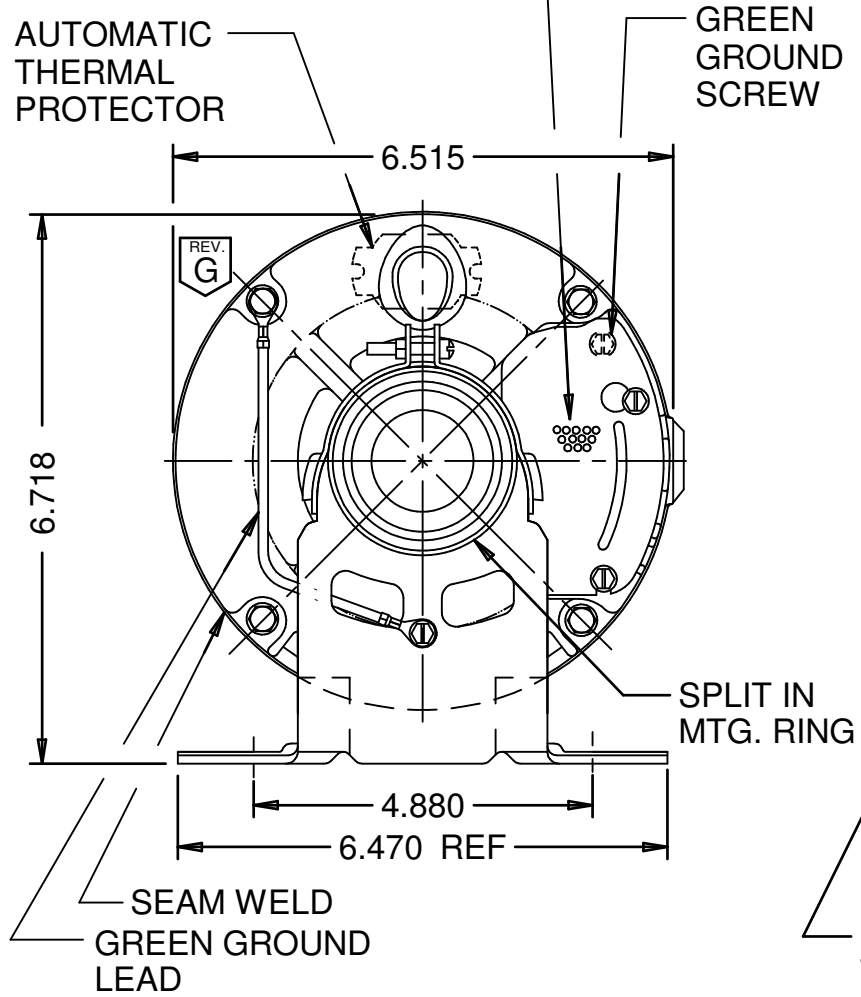

NIDEC MOTOR CORPORATION 16-Mar-18

MODEL	REF	CUSTOMER	HP	VOLTS	AMPS	HZ	RPM	ROTATION	CUSTOMER PN
P63ZZWBD-4227	M21309	STANDARD	1	208-230/460	4.3/2.2	60	1725	REVERSIBLE	8498

SHEET NUMBER	REV	REVISION RECORD FOR: ECO E30649		
1 OF 1	G	CHANGED VIEW GROUND LEAD TO BEHIND OF THE BASE		
REVISION DATE				
21-MAR-18				
ISSUED BY	REVIEWED BY	ENGINEER APPROVED		
C. LUGO	F. FLORES	B. GAITAN		

INFORMATION DISCLOSED ON THIS DOCUMENT IS CONSIDERED PROPRIETARY AND SHALL NOT BE REPRODUCED OR DISCLOSED WITHOUT WRITTEN CONSENT OF NIDEC MOTOR CORPORATION

**NIDEC MOTOR CORPORATION**

ALL DIMENSIONS ARE FOR REFERENCE ONLY UNLESS TOLERANCE IS GIVEN			
TITLE	CODE	ITEM NO.	SIZE
ASSEMBLED VIEW	V01	758712	A