

6 LEADS, #18, .031 THICK INSUL. TO EXTEND BEYOND MOTOR.
 WHITE (C)=54.000+3-0, BLACK (1)=54.000+3-0
 YELLOW (2)=54.000+3-0, BLUE (3)=54.000+3-0
 ORANGE (4)=54.000+3-0, RED (5)=54.000+3-0

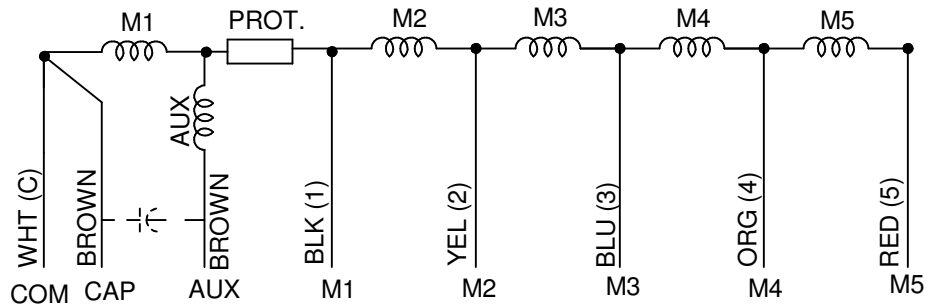

NIDEC MOTOR CORPORATION 14-Nov-17

MODEL	REF	CUSTOMER	HP	VOLTS	AMPS	HZ	RPM	ROTATION	CUSTOMER PN
K48HXWGM-4384	A27631-X3	WHOLESALE - HAC	1/10	115	2.5	60	1050/5 SPD	CW LEAD END	2827P

SHEET NUMBER	REV	REVISION RECORD FOR: ECO: E29762	
1 OF 1	F	CHANGE DRAWING TO SHOW THAT THE GROUND WIRE IS ROUTED FROM INSIDE THE BASE	
REVISION DATE			
15-NOV-17			
ISSUED BY	REVIEWED BY	ENGINEER APPROVED	
J. ALVARADO	R. CRUZ	B. GAITAN	

INFORMATION DISCLOSED ON THIS DOCUMENT IS CONSIDERED PROPRIETARY AND SHALL NOT BE REPRODUCED OR DISCLOSED WITHOUT WRITTEN CONSENT OF NIDEC MOTOR CORPORATION

ALL DIMENSIONS ARE FOR REFERENCE ONLY UNLESS TOLERANCE IS GIVEN

TITLE	CODE	ITEM NO.	SIZE
ASSEMBLED VIEW	V01	776562	A

NIDEC MOTOR CORPORATION	
ITEM NO.	776562