

6 LEADS, #18, .031 THICK INSUL. TO EXTEND BEYOND MOTOR.  
 WHITE =54.000+3-0, BLACK =54.000+3-0  
 YELLOW =54.000+3-0, BLUE =54.000+3-0  
 ORANGE =54.000+3-0, RED =54.000+3-0

#16, GRN/YEL GRD LEAD TO BE 10.000±.250 BETWEEN CENTERS OF TERMS., TERM. TO FIT #10 SCREW.

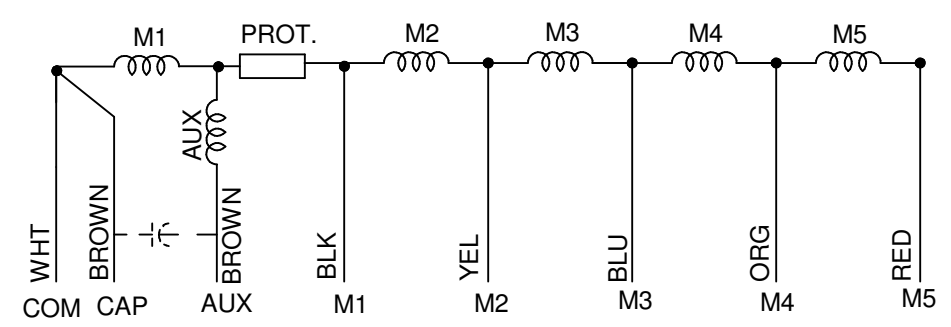
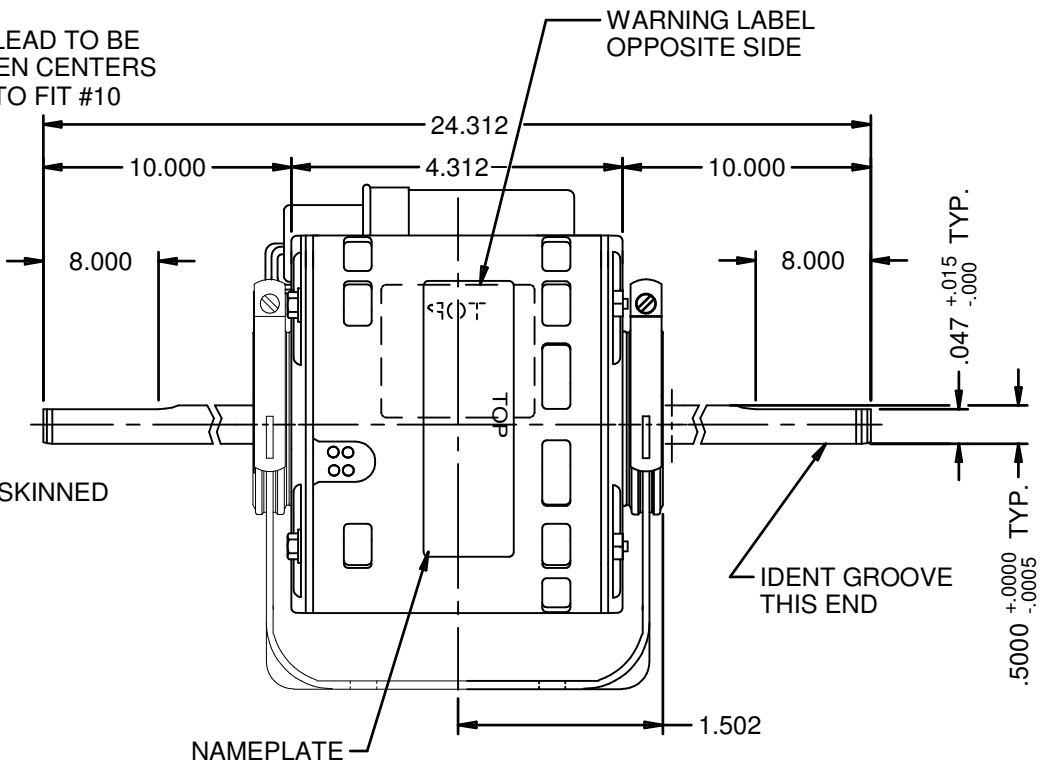

NIDEC MOTOR CORPORATION 14-Nov-17											CAPACITOR 5 MFD, 370 VAC	
MODEL	REF	CUSTOMER	HP	VOLTS	AMPS	HZ	RPM	ROTATION	CUSTOMER PN			
K48HXWGM-0192	A32829	NIDEC MOTOR CANADA CORPORATION	1/10	115	2.5	60	1050/5 SPD	CW LEAD END	2832			
SHEET NUMBER 1 OF 1	REV F	REVISION RECORD FOR: ECO: E29762				INFORMATION DISCLOSED ON THIS DOCUMENT IS CONSIDERED PROPRIETARY AND SHALL NOT BE REPRODUCED OR DISCLOSED WITHOUT WRITTEN CONSENT OF NIDEC MOTOR CORPORATION				NIDEC MOTOR CORPORATION		
CHANGE DRAWING TO SHOW THAT THE GROUND WIRE IS ROUTED FROM INSIDE THE BASE												
REVISION DATE												
15-NOV-17						ALL DIMENSIONS ARE FOR REFERENCE ONLY UNLESS TOLERANCE IS GIVEN						
ISSUED BY J. ALVARADO	REVIEWED BY R. CRUZ	ENGINEER APPROVED H. O. NAVARRO	TITLE ASSEMBLED VIEW				CODE V01	ITEM NO. 790820	SIZE A			