

VAR	MODEL	CUSTOMER	CAT. NO.	A	B	C	D	HP	VOLTS	SF	AMPS	HZ	RPM	CONN VOLTS	PROT.	DESCRIPTION / REMARKS
001	P55DHN-1583	USEM	D12P2D	10.439	-----	-----	-----	1/2	208-230/460	1.0	2.0-2.0/1.0	60&50	1725&1425	230	NONE	N56, ODP

SHAFT KEY TAPED TO MOTOR

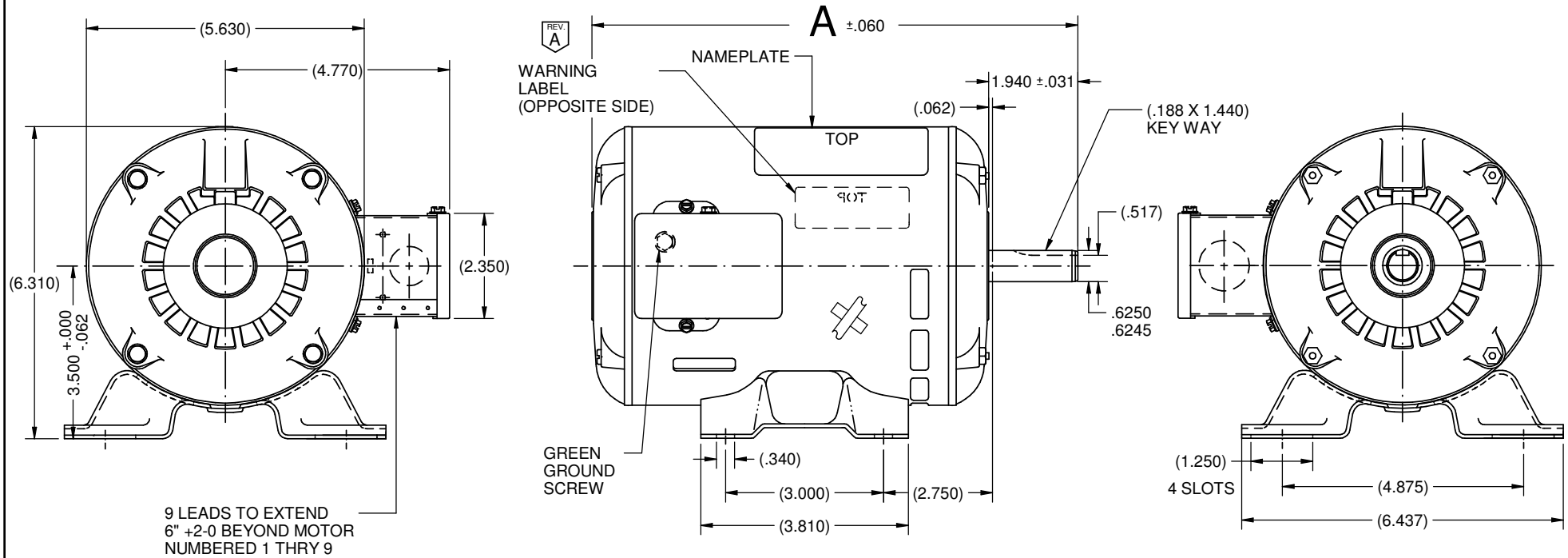

ROTATION: REVERSIBLE

REFER TO S.E.I.M. 24-1

NIDEC MOTOR CORPORATION 08-May-15

UPDATED NOTE	REVISION RECORD FOR:	22868
ISSUED BY:	ENGINEER APPROVED:	
M. MEDINA	M. SCHUETTE	

TOLERANCES ON DIMENSIONS (UNLESS OTHERWISE SPECIFIED)	
INCHES .XX = ±.010 .XXX = ±.005	mm
ANGLES X° = ±1°	

NIDEC MOTOR CORPORATION			
INFORMATION DISCLOSED ON THIS DOCUMENT IS CONSIDERED PROPRIETARY AND SHALL NOT BE REPRODUCED OR DISCLOSED WITHOUT WRITTEN CONSENT OF NIDEC MOTOR CORPORATION			
TITLE		CODE	ITEM NO.
CUSTOMER DETAIL DRAWING		V02	803873
REVISION DATE:	REV	SHEET NUMBER	DWG SIZE
08-MAY-15	A	1 OF 4	B