

MODEL	REF	CUSTOMER	HP	VOLTS	AMPS	HZ	RPM	ROTATION	CATALOG NO.	DESCRIPTION / REMARKS
K55HXRNC-2263	C41746	WHOLESALE HAC	1/6	115	1.43	60	775/3 SPD	CCW LEAD END	1415	K55 RES. MTD., SELF ALIGN BRG., OPEN

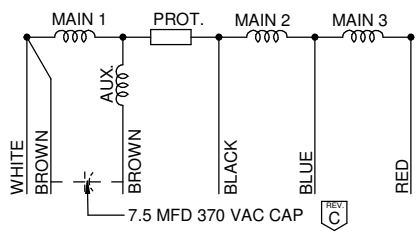
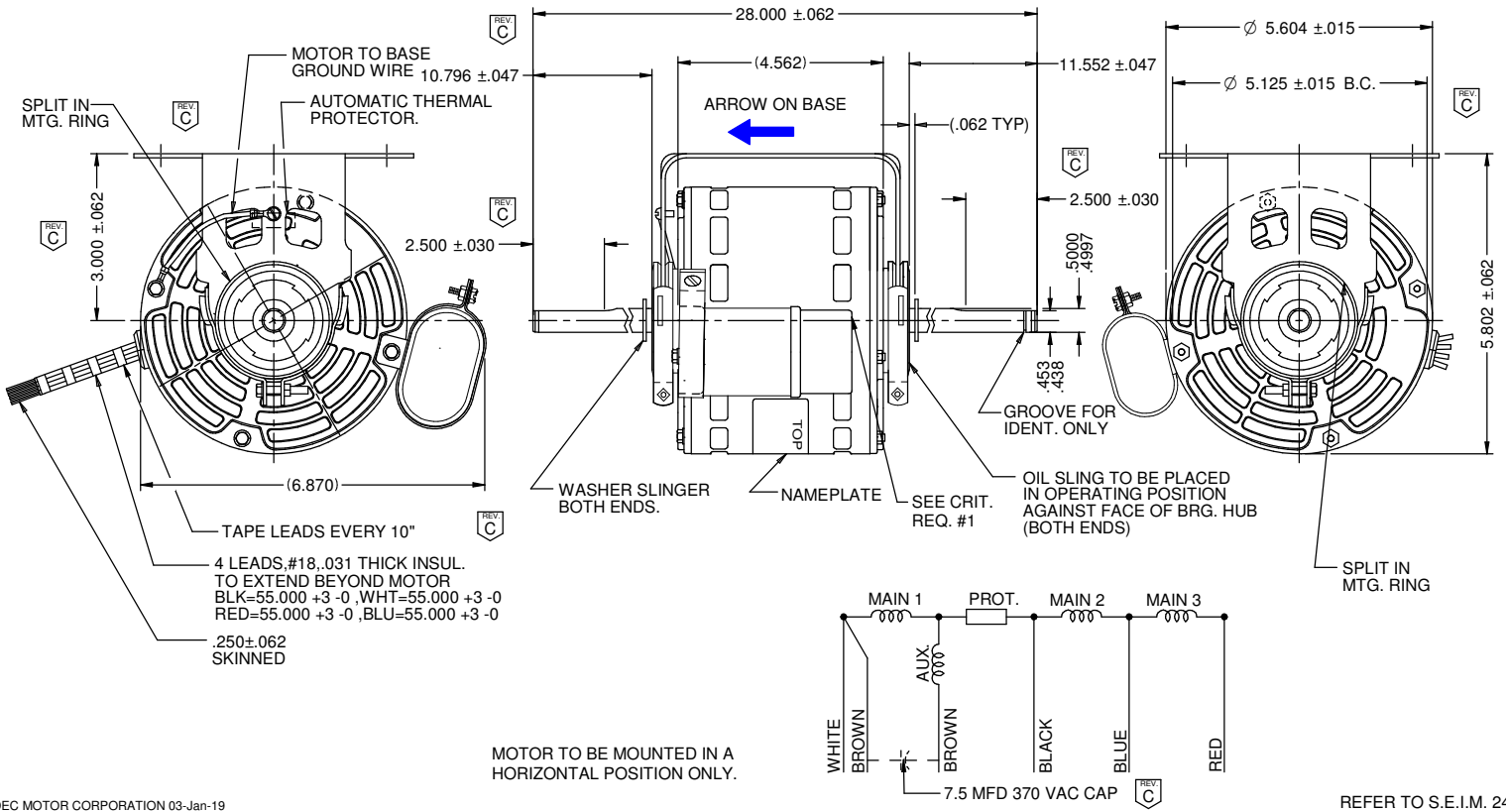

NIDEC MOTOR CORPORATION 03-Jan-19		REVISION RECORD FOR: ECO E32354		TOLERANCES ON DIMENSIONS (UNLESS OTHERWISE SPECIFIED):		NIDEC MOTOR CORPORATION							
SEVERAL DIMENSIONS AND NOTES WERE UPDATED. CONNECTION DIAGRAM WAS ADDED TO PAGE #3.		INCHES .XX = ±.010 .XXX = ±.005		mm		INFORMATION DISCLOSED ON THIS DOCUMENT IS CONSIDERED PROPRIETARY AND SHALL NOT BE REPRODUCED OR DISCLOSED WITHOUT WRITTEN CONSENT OF NIDEC MOTOR CORPORATION							
ISSUED BY: G. TREVIÑO		ENGINEER APPROVED: D. TEJEDA		ANGLES X° = ±1°		TITLE: CUSTOMER DETAIL DRAWING		CODE: V02	ITEM NO.: 807431	REV: C	REVISION DATE: 03-JAN-19	SHEET NUMBER: 1 OF 3	DWG SIZE: B

V02_NMCB (MAR.2014)

SOLIDEDGE