

CATALOG #	NIDEC MODEL	REVCOR NUMBER	FAN DIA. "D"	PITCH	A HUB WIDTH	G SCREW LOCATOR	W BLADE WIDTH	BORE DIA.	DESCRIPTION/REMARKS
US4A3024	Z298041400025OL	607530	30	24	0.81	0.28	2.75	.625	CW
US4B3024	Z298041400026OL	607531	30	24	0.81	0.28	2.75	.625	CCW

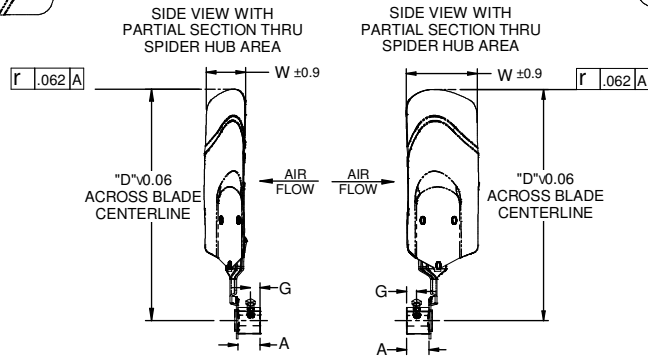
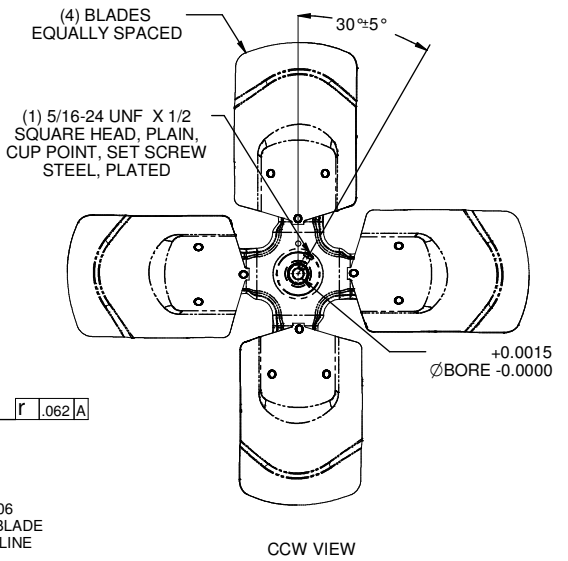
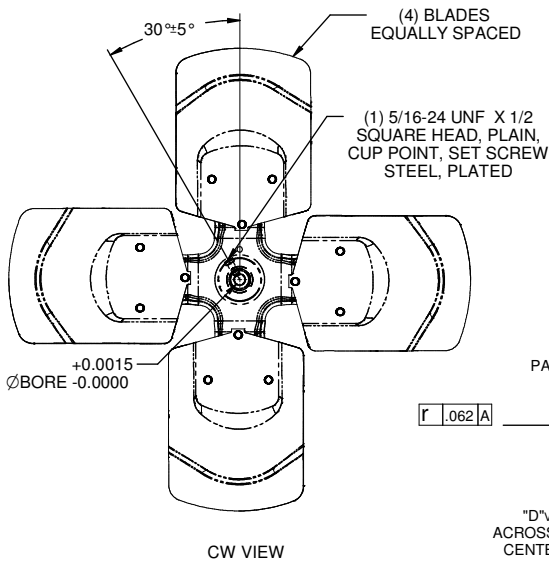

NIDEC MOTOR CORPORATION 08-OCT-15

NEW DRAWING	REVISION RECORD FOR:	F24789
ISSUED BY:	ENGINEER APPROVED:	
H. PEÑA	T. BOURQUIN	

TOLERANCES ON DIMENSIONS (UNLESS OTHERWISE SPECIFIED):	
INCHES .XX = ±.010 .XXX = ±.005	mm
ANGLES X° ±1°	

NIDEC MOTOR CORPORATION			
INFORMATION DISCLOSED ON THIS DOCUMENT IS CONSIDERED PROPRIETARY AND SHALL NOT BE REPRODUCED OR DISCLOSED WITHOUT WRITTEN CONSENT OF NIDEC MOTOR CORPORATION			
TITLE		CODE	REVISION DATE:
CUSTOMER DETAIL DRAWING		V02	18-FEB-16
ITEM NO.	REV	SHEET NUMBER	DWG SIZE
810034	--	1 OF 2	B

V02_NMCB (MAR-2014)

SOLIDEDGE