

VAR	MODEL	CUSTOMER	CUSTOMER PN.	A	B	C	D	HP	VOLTS	SF	AMPS	HZ	RPM	CONN VOLTS	PROT.	DESCRIPTION / REMARKS
001	S55KXTGK-7806	STANDARD	5866	7.818	5.843	--	--	1/7	115	--	2.6	60	3450	--	MANUAL	--

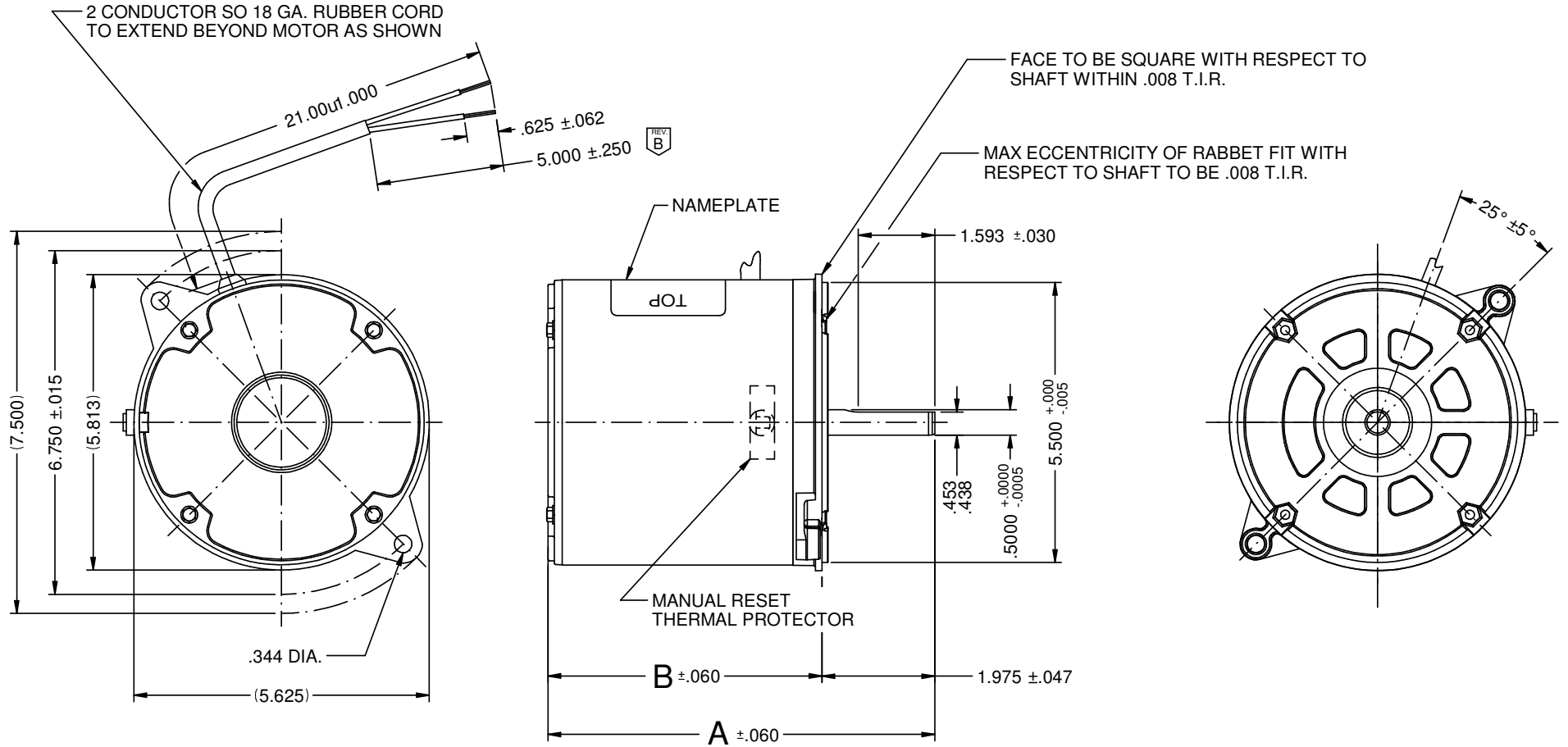

NIDEC MOTOR CORPORATION 14-Nov-18

ROTACION: CCW DRIVE-END

REFER TO S.E.I.M. 24-1

REVISION RECORD FOR:	ECO-E32851
CHANGE CORD DIMENSION FROM 5.500 TO 5.000	

TOLERANCES ON DIMENSIONS  
(UNLESS OTHERWISE SPECIFIED)

INCHES  
.XX = ±.010  
.XXX = ±.005

mm

ANGLES X° = ±1°

**NIDEC MOTOR CORPORATION**

INFORMATION DISCLOSED ON THIS DOCUMENT IS CONSIDERED PROPRIETARY AND SHALL NOT BE REPRODUCED OR DISCLOSED WITHOUT WRITTEN CONSENT OF NIDEC MOTOR CORPORATION

REVISION DATE:  
14-NOV-18

ISSUED BY:	A.GARCIA	ENGINEER APPROVED:	L.BACHMAN
------------	----------	--------------------	-----------

TITLE	CODE	ITEM NO.	REV	SHEET NUMBER	DWG SIZE
CUSTOMER DETAIL DRAWING	V02	810154	B	1 OF 4	B